

ESP32-H2-WROOM-02C

Datasheet

Bluetooth® Low Energy and IEEE 802.15.4 module

Built around ESP32-H2 series of SoCs, RISC-V single-core 32-bit microprocessor

2 MB or 4 MB flash in chip package

19 GPIOs

On-board PCB antenna



ESP32-H2-WROOM-02C



Pre-release v0.6
Espressif Systems
Copyright © 2023

1 Module Overview

Note:

Check the link or the QR code to make sure that you use the latest version of this document:
https://espressif.com/sites/default/files/documentation/esp32-h2-wroom-02c_datasheet_en.pdf



1.1 Features

CPU and On-Chip Memory

- ESP32-H2 embedded, RISC-V single-core 32-bit LX7 microprocessor, up to 96 MHz
- 128 KB ROM
- 320 KB SRAM
- 4 KB LP Memory
- 2 MB or 4 MB in-package flash

Bluetooth

- Bluetooth Low Energy (Bluetooth 5.3 certified)
- Bluetooth mesh
- Bluetooth Low Energy long range (Coded PHY, 125 Kbps and 500 Kbps)
- Bluetooth Low Energy high speed (2 Mbps)
- Bluetooth Low Energy advertising extensions and multiple advertising sets
- Simultaneous Broadcaster, Observer, Peripheral and Central
- Multiple connections
- LE power control

IEEE 802.15.4

- IEEE Standard 802.15.4-2015 compliant
- Supports 250 Kbps data rate in 2.4 GHz band and OQPSK PHY

- Supports Thread 1.3
- Supports Zigbee 3.0
- Supports Matter
- Supports other application-layer protocols (HomeKit, MQTT, etc)

Peripherals

- GPIO, I2C, I2S, SPI, UART, ADC, LED PWM, ETM, GDMA, PCNT, PARLIO, RMT, TWAI®, MCPWM, USB Serial/JTAG, temperature sensor, general-purpose timers, system timer, watchdog timer

Note:

* Please refer to [ESP32-H2 Series Datasheet](#) for detailed information about the module peripherals.

Integrated Components on Module

- 32 MHz crystal oscillator

Antenna Options

- On-board PCB antenna

Operating Conditions

- Operating voltage/Power supply: 3.0 ~ 3.6 V
- Operating ambient temperature: -40 ~ 105 °C

1.2 Description

ESP32-H2-WROOM-02C is a powerful, generic Bluetooth® Low Energy and IEEE 802.15.4 combo module that has a rich set of peripherals. This module is an ideal choice for a wide variety of application scenarios related to Internet of Things (IoT), such as embedded systems, smart home, wearable electronics, etc.

ESP32-H2-WROOM-02C comes with a PCB antenna.

The series comparison for ESP32-H2-WROOM-02C is as follows:

Table 1: ESP32-H2-WROOM-02C Series Comparison

Ordering Code	In-package Flash	Ambient Temp. ¹ (°C)	Size ² (mm)
ESP32-H2-WROOM-02C-H2	2 MB	-40 ~105	20.0 × 18.0 × 3.2
ESP32-H2-WROOM-02C-H4	4 MB		

¹ Ambient temperature specifies the recommended temperature range of the environment immediately outside the Espressif module.

² For details, refer to Section [8.1 Physical Dimensions](#).

ESP32-H2-WROOM-02C has integrated the ESP32-H2 chip, which has a 32-bit RISC-V single-core CPU that operates at up to 96 MHz. You can power off the CPU and make use of the low-power coprocessor to constantly monitor the peripherals for changes or crossing of thresholds.

ESP32-H2 integrates a rich set of peripherals including I2C, I2S, SPI, UART, ADC, LED PWM, ETM, GDMA, PCNT, PARLIO, RMT, TWAI, MCPWM, USB Serial/JTAG, temperature sensor, general-purpose timers, system timer, watchdog timer as well as up to 19 GPIOs.

Note:

For more information on ESP32-H2 chip, please refer to [ESP32-H2 Series Datasheet](#).

1.3 Applications

- Smart Home
- Industrial Automation
- Health Care
- Consumer Electronics
- Smart Agriculture
- Retail and Catering
- Generic Low-power IoT Sensor Hubs
- Generic Low-power IoT Data Loggers

Contents

1	Module Overview	2
1.1	Features	2
1.2	Description	3
1.3	Applications	3
2	Block Diagram	8
3	Pin Definitions	9
3.1	Pin Layout	9
3.2	Pin Description	9
3.3	Strapping Pins	10
3.3.1	Chip Boot Mode Control	11
3.3.2	ROM Messages Printing Control	11
3.3.3	JTAG Signal Source Control	12
4	Electrical Characteristics	14
4.1	Absolute Maximum Ratings	14
4.2	Recommended Operating Conditions	14
4.3	DC Characteristics (3.3 V, 25 °C)	14
4.4	Current Consumption Characteristics	15
4.4.1	Current Consumption in Active Mode	15
4.4.2	Current Consumption in Other Modes	16
5	RF Characteristics	17
5.1	Bluetooth 5 (LE) Radio	17
5.1.1	Bluetooth LE RF Transmitter (TX) Characteristics	17
5.1.2	Bluetooth LE RF Receiver (RX) Characteristics	19
5.2	802.15.4 Radio	21
5.2.1	802.15.4 RF Transmitter (TX) Characteristics	21
5.2.2	802.15.4 RF Receiver (RX) Characteristics	21
6	Module Schematics	22
7	Peripheral Schematics	23
8	Physical Dimensions and PCB Land Pattern	24
8.1	Physical Dimensions	24
8.2	Recommended PCB Land Pattern	25
9	Product Handling	26
9.1	Storage Conditions	26
9.2	Electrostatic Discharge (ESD)	26
9.3	Soldering Profile	26

9.3.1	Reflow Profile	26
9.4	Ultrasonic Vibration	27
10	Related Documentation and Resources	28
	Revision History	29

PRELIMINARY

List of Tables

1	ESP32-H2-WROOM-02C Series Comparison	3
2	Pin Definitions	9
3	Default Configuration of Strapping Pins	11
4	Boot Mode Control	11
5	ROM Message Printing Control	12
6	JTAG Signal Source Control	12
7	Parameter Descriptions of the Setup and Hold Time for the Strapping Pin	13
8	Absolute Maximum Ratings	14
9	Recommended Operating Conditions	14
10	DC Characteristics (3.3 V, 25 °C)	14
11	Current Consumption for Bluetooth LE in Active Mode	15
12	Current Consumption for 802.15.4 in Active Mode	15
13	Current Consumption in Modem-sleep Mode	16
14	Current Consumption in Low-Power Modes	16
15	Bluetooth LE RF Characteristics	17
16	Bluetooth LE - Transmitter Characteristics - 1 Mbps	17
17	Bluetooth LE - Transmitter Characteristics - 2 Mbps	17
18	Bluetooth LE - Transmitter Characteristics - 125 Kbps	18
19	Bluetooth LE - Transmitter Characteristics - 500 Kbps	18
20	Bluetooth LE - Receiver Characteristics - 1 Mbps	19
21	Bluetooth LE - Receiver Characteristics - 2 Mbps	19
22	Bluetooth LE - Receiver Characteristics - 125 Kbps	20
23	Bluetooth LE - Receiver Characteristics - 500 Kbps	20
24	802.15.4 RF Characteristics	21
25	802.15.4 Transmitter Characteristics - 250 Kbps	21
26	802.15.4 Receiver Characteristics - 250 Kbps	21

List of Figures

1	Block Diagram	8
2	Pin Layout (Top View and Bottom View)	9
3	Setup and Hold Times for the Strapping Pin	13
4	Schematics	22
5	Peripheral Schematics	23
6	Physical Dimensions	24
7	Recommended PCB Land Pattern	25
8	Reflow Profile	27

PRELIMINARY

2 Block Diagram

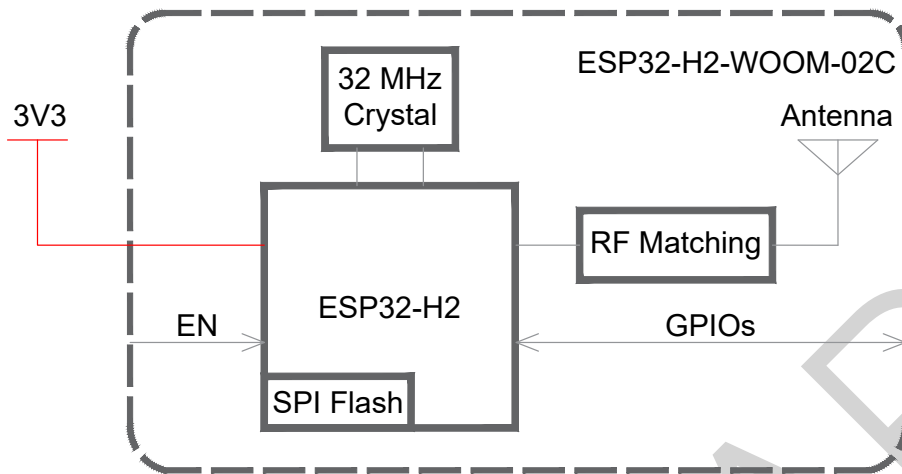

Figure 1: Block Diagram

3 Pin Definitions

3.1 Pin Layout

The pin diagram below shows the approximate location of pins on the module. For the actual diagram drawn to scale, please refer to Figure 8.1 *Physical Dimensions*.

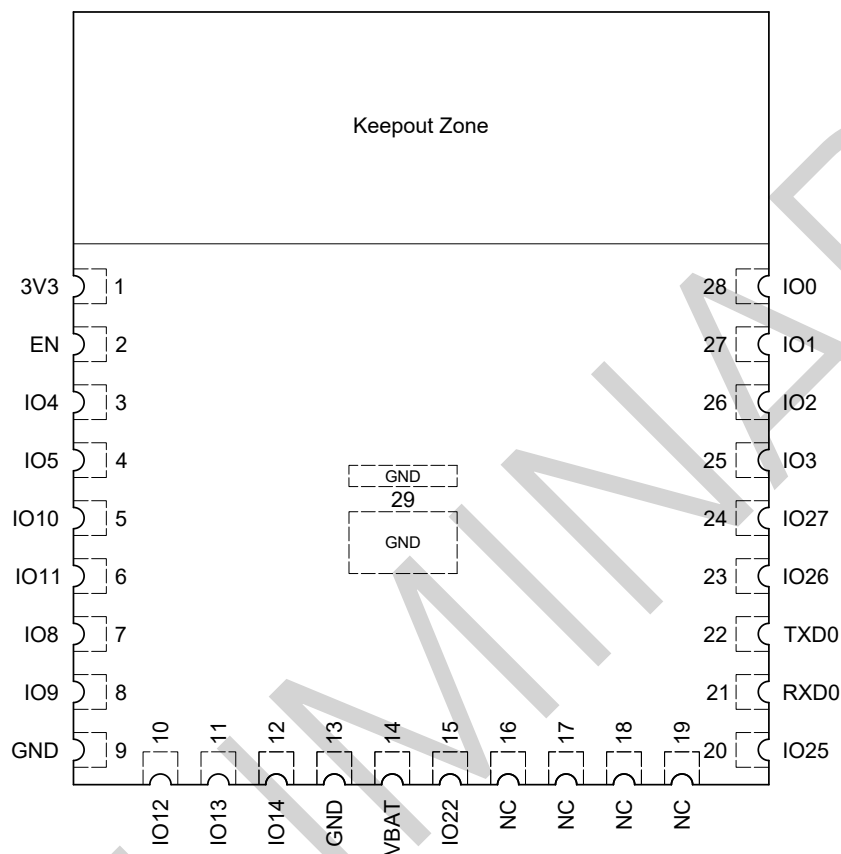

Figure 2: Pin Layout (Top View and Bottom View)

3.2 Pin Description

The module has 29 pins. See pin definitions in Table 2 *Pin Description*.

For peripheral pin configurations, please refer to [ESP32-H2 Series Datasheet](#).

Table 2: Pin Definitions

Name	No.	Type ¹	Function
3V3	1	P	Power supply
EN	2	I	High: on, enables the chip. Low: off, the chip powers off. Note: Do not leave the EN pin floating.
IO4	3	I/O/T	GPIO4, FSPICLK, ADC1_CH3, MTCK
IO5	4	I/O/T	GPIO5, FSPID, ADC1_CH4, MTDI

Cont'd on next page

Table 2 – cont'd from previous page

Name	No.	Type ¹	Function
IO10	5	I/O/T	GPIO10 , ZCDO
IO11	6	I/O/T	GPIO11 , ZCD1
IO8	7	I/O/T	GPIO8
IO9	8	I/O/T	GPIO9
GND	9, 13, 29	P	Ground
IO12	10	I/O/T	GPIO12
IO13	11	I/O/T	GPIO13 , XTAL_32K_P
IO14	12	I/O/T	GPIO14 , XTAL_32K_N
VBAT	14	P	Connected to internal 3V3 power supply (Default) or external battery power supply (3.0 ~ 3.6 V).
IO22	15	I/O/T	GPIO22
NC	16 ~19	—	NC
IO25	20	I/O/T	GPIO25 , FSPICS3
RXD0	21	I/O/T	GPIO23, FSPICS1, UORXD
TXD0	22	I/O/T	GPIO24, FSPICS2, UOTXD
IO26	23	I/O/T	GPIO26, FSPICS4, USB_D-
IO27	24	I/O/T	GPIO27, FSPICS5, USB_D+
IO3	25	I/O/T	GPIO3, FSPiHD, ADC1_CH2, MTDO
IO2	26	I/O/T	GPIO2, FSPiWP, ADC1_CH1, MTMS
IO1	27	I/O/T	GPIO1 , FSPICS0, ADC1_CHO
IO0	28	I/O/T	GPIO0 , FSPiQ

3.3 Strapping Pins

Note:

The content below is excerpted from [ESP32-H2 Series Datasheet](#) > Section *Strapping Pins*. For the strapping pin mapping between the chip and modules, please refer to Chapter [6 Module Schematics](#).

At each startup or reset, a chip requires some initial configuration parameters, such as in which boot mode to load the chip, etc. These parameters are passed over via the strapping pins. After reset, the strapping pins work as normal function pins.

ESP32-H2 has the following parameters controlled by the given strapping pins at chip reset:

- **Chip boot mode** – GPIO8 and GPIO9
- **ROM message printing** – GPIO8
- **JTAG signal source** – GPIO25

GPIO9 is connected to the chip's internal weak pull-up resistor at chip reset. This resistor determines the default bit value of GPIO9. Also, the resistor determines the bit value if GPIO9 is connected to an external high-impedance circuit.

Table 3: Default Configuration of Strapping Pins

Strapping Pin	Default Config	Bit Value
GPIO8	Floating	–
GPIO9	Pull-up	1
GPIO25	Floating	–

To change the bit values, the strapping pins should be connected to external pull-down/pull-up resistances. If the ESP32-H2 is used as a device by a host MCU, the strapping pin voltage levels can also be controlled by the host MCU.

All strapping pins have latches. At system reset, the latches sample the bit values of their respective strapping pins and store them until the chip is powered down or shut down. The states of latches cannot be changed in any other way. It makes the strapping pin values available during the entire chip operation, and the pins are freed up to be used as regular IOs after reset.

3.3.1 Chip Boot Mode Control

After the reset is released, the combination of GPIO8 and GPIO9 controls the boot mode. See Table 4 [Boot Mode Control](#).

Table 4: Boot Mode Control

Boot Mode	GPIO8	GPIO9
Default Config	– (Floating)	1 (Pull-up)
SPI Boot	Any value	1
Joint Download Boot ¹	1	0

¹ Joint Download Boot mode supports the following download methods:

- USB-Serial-JTAG Download Boot
- UART Download Boot

In SPI Boot mode, the ROM bootloader loads and executes the program from SPI flash to boot the system.

In Joint Download Boot mode, users can download binary files into flash using UART0 or USB interface. It is also possible to download binary files into SRAM and execute it from SRAM.

In addition to SPI Boot and Joint Download Boot modes, ESP32-H2 also supports SPI Download Boot mode. For details, please see [ESP32-H2 Technical Reference Manual](#) > Chapter *Chip Boot Control*.

3.3.2 ROM Messages Printing Control

During the ROM boot stage of SPI Boot mode, GPIO8, LP_AON_STORE4_REG[0] and EFUSE_UART_PRINT_CONTROL jointly control the printing of ROM messages.

Table 5: ROM Message Printing Control

Register ¹	eFuse ²	GPIO8	ROM Message Printing
0	0 (0b00)	x ³	ROM messages are always printed to UART0 during boot
	1 (0b01)	0	Print is enabled during boot
		1	Print is disabled during boot
	2 (0b10)	0	Print is disabled during boot
		1	Print is enabled during boot
3 (0b11)	x	Print is disabled during boot	
1	x	x	Print is disabled during boot

¹ Register: LP_AON_STORE4_REG[0]

² eFuse: EFUSE_UART_PRINT_CONTROL

³ x: x indicates that the value has no effect on the result and can be ignored.

ROM message is printed to UART0 and USB Serial/JTAG Controller by default during power-on. Users can disable the printing to USB Serial/JTAG Controller by setting the eFuse bit EFUSE_DIS_USB_SERIAL_JTAG_ROM_PRINT.

Note that if EFUSE_DIS_USB_SERIAL_JTAG_ROM_PRINT is set to 0 to print to USB, but the USB Serial/JTAG Controller has been disabled, then ROM messages will not be printed to USB Serial/JTAG Controller.

Detailed description about the above-mentioned registers can be found in [ESP32-H2 Technical Reference Manual](#) > Chapter eFuse Controller (EFUSE).

3.3.3 JTAG Signal Source Control

The strapping pin GPIO25 can be used to control the source of JTAG signals during the early boot process. This pin does not have any internal pull resistors and the strapping value must be controlled by the external circuit that cannot be in a high impedance state.

As Table 6 shows, GPIO25 is used in combination with EFUSE_DIS_PAD_JTAG, EFUSE_DIS_USB_JTAG, and EFUSE_JTAG_SEL_ENABLE.

Table 6: JTAG Signal Source Control

eFuse 1a	eFuse 2b	eFuse 3c	GPIO25	JTAG Signal Source
0	0	0	Ignored	USB Serial/JTAG Controller
		1	0	JTAG pins MTDI, MTCK, MTMS, and MTDO
			1	USB Serial/JTAG Controller
0	1	Ignored	Ignored	JTAG pins MTDI, MTCK, MTMS, and MTDO
1	0	Ignored	Ignored	USB Serial/JTAG Controller
1	1	Ignored	Ignored	JTAG is disabled

a eFuse 1: EFUSE_DIS_PAD_JTAG

b eFuse 2: EFUSE_DIS_USB_JTAG

c eFuse 3: EFUSE_JTAG_SEL_ENABLE

Detailed description about the above-mentioned registers can be found in

[ESP32-H2 Technical Reference Manual](#) > Chapter eFuse Controller (EFUSE).

Figure 3 shows the setup and hold time for the strapping pin before and after the CHIP_EN signal goes high. Details about the parameters are listed in Table 7.

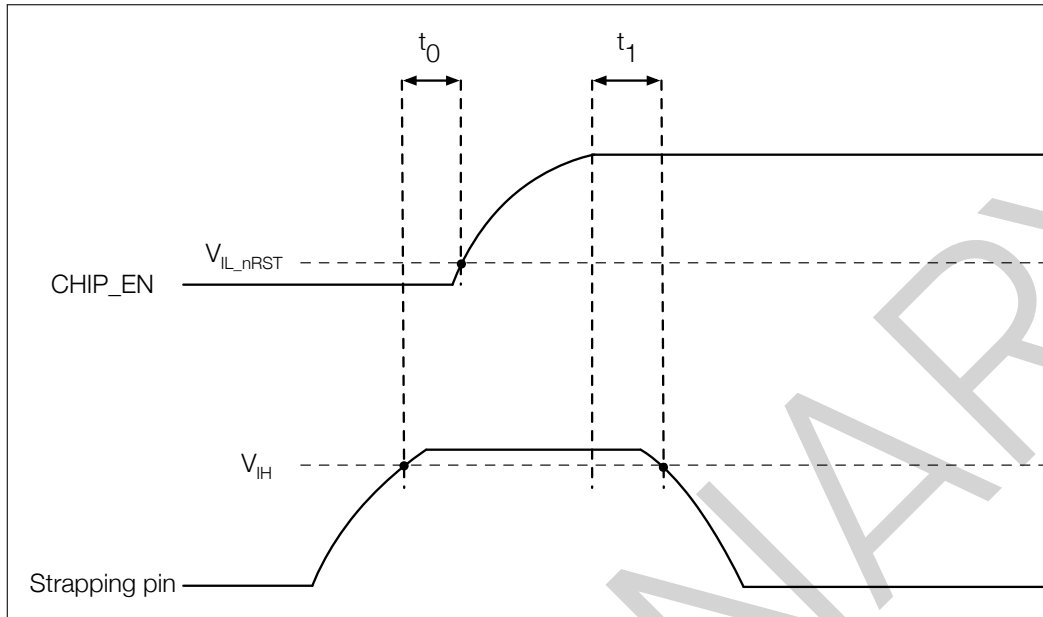

Figure 3: Setup and Hold Times for the Strapping Pin

Table 7: Parameter Descriptions of the Setup and Hold Time for the Strapping Pin

Parameter	Description	Min (ms)
t_0	Setup time before CHIP_EN goes from low to high	0
t_1	Hold time after CHIP_EN goes high	3

4 Electrical Characteristics

The values presented in this section are preliminary and may change with the final release of this datasheet.

4.1 Absolute Maximum Ratings

Stresses above those listed in Table 8 *Absolute Maximum Ratings* may cause permanent damage to the device. These are stress ratings only and functional operation of the device at these or any other conditions beyond those indicated under Table 9 *Recommended Operating Conditions* is not implied. Exposure to absolute-maximum-rated conditions for extended periods may affect device reliability.

Table 8: Absolute Maximum Ratings

Symbol	Parameter	Min	Max	Unit
VDD33	Power supply voltage	-0.3	3.6	V
T _{STORE}	Storage temperature	-40	105	°C

4.2 Recommended Operating Conditions

Table 9: Recommended Operating Conditions

Symbol	Parameter	Min	Typ	Max	Unit
VDD33	Power supply voltage	3.0	3.3	3.6	V
I _{VDD}	Current delivered by external power supply	0.5	—	—	A
T _A	Operating ambient temperature	-40	—	105	°C

4.3 DC Characteristics (3.3 V, 25 °C)

Table 10: DC Characteristics (3.3 V, 25 °C)

Symbol	Parameter	Min	Typ	Max	Unit
C _{IN}	Pin capacitance	—	2	—	pF
V _{IH}	High-level input voltage	0.75 × VDD ¹	—	VDD ¹ + 0.3	V
V _{IL}	Low-level input voltage	-0.3	—	0.25 × VDD ¹	V
I _{IH}	High-level input current	—	—	50	nA
I _{IL}	Low-level input current	—	—	50	nA
V _{OH} ²	High-level output voltage	0.8 × VDD ¹	—	—	V
V _{OL} ²	Low-level output voltage	—	—	0.1 × VDD ¹	V
I _{OH}	High-level source current (VDD ¹ = 3.3 V, V _{OH} ≥ 2.64 V, PAD_DRIVER = 3)	—	40	—	mA
I _{OL}	Low-level sink current (VDD ¹ = 3.3 V, V _{OL} = 0.495 V, PAD_DRIVER = 3)	—	28	—	mA
R _{PU}	Pull-up resistor	—	45	—	kΩ
R _{PD}	Pull-down resistor	—	45	—	kΩ

V_{IH_nRST}	Chip reset release voltage	$0.75 \times VDD^1$	—	$VDD^1 + 0.3$	V
V_{IL_nRST}	Chip reset voltage	-0.3	—	$0.25 \times VDD^1$	V

¹ VDD is the I/O voltage for pins of a particular power domain.

² V_{OH} and V_{OL} are measured using high-impedance load.

4.4 Current Consumption Characteristics

4.4.1 Current Consumption in Active Mode

The current consumption measurements are taken with a 3.3 V supply at 25 °C ambient temperature.

TX current consumption is rated at a 100% duty cycle.

RX current consumption is rated when the peripherals are disabled and the CPU idle.

Table 11: Current Consumption for Bluetooth LE in Active Mode

Work Mode	RF Condition	Description	Peak (mA)
Active (RF working)	TX	Bluetooth LE @ 20.0 dBm	140
		Bluetooth LE @ 9.0 dBm	60
		Bluetooth LE @ 0 dBm	36
		Bluetooth LE @ -24.0 dBm	24
	RX	Bluetooth LE	24

Table 12: Current Consumption for 802.15.4 in Active Mode

Work Mode	RF Condition	Description	Peak (mA)
Active (RF working)	TX	802.15.4 @ 20.0 dBm	140
		802.15.4 @ 9.0 dBm	60
		802.15.4 @ 0 dBm	36
		802.15.4 @ -24.0 dBm	24
	RX	802.15.4	26

Note:

The content below is excerpted from *Section Power Consumption in Other Modes* in [ESP32-H2 Series Datasheet](#).

4.4.2 Current Consumption in Other Modes

Table 13: Current Consumption in Modem-sleep Mode

Mode	CPU Frequency (MHz)	Description	Typ (mA)	
			All Peripherals Clocks Disabled	All Peripherals Clocks Enabled ¹
Modem-sleep ²	96	CPU is running	10	17
		CPU is idle	6	13
	64	CPU is running	8	13
		CPU is idle	5	10
	48	CPU is running	7	11
		CPU is idle	5	9
	32	CPU is running	4	8
		CPU is idle	3	7

Table 14: Current Consumption in Low-Power Modes

Mode	Description	Typ (μ A)
Light-sleep	CPU and wireless communication modules are powered down, peripheral clocks are disabled, and all GPIOs are high-impedance	85
	CPU, wireless communication modules and peripherals are powered down, and all GPIOs are high-impedance	25
Deep-sleep	LP timer and LP memory are powered on	7
Power off	CHIP_EN is set to low level, the chip is powered off	1

5 RF Characteristics

This section contains tables with RF characteristics of the Espressif product.

The RF data is measured at the antenna port, where RF cable is connected, including the front-end loss. The external antennas used for the tests on the modules with external antenna connectors have an impedance of 50 Ω .

Devices should operate in the center frequency range allocated by regional regulatory authorities. The target center frequency range and the target transmit power are configurable by software. See [ESP RF Test Tool and Test Guide](#) for instructions.

Unless otherwise stated, the RF tests are conducted with a 3.3 V ($\pm 5\%$) supply at 25 $^{\circ}\text{C}$ ambient temperature.

5.1 Bluetooth 5 (LE) Radio

Table 15: Bluetooth LE RF Characteristics

Name	Description
Center frequency range of operating channel	2402 ~ 2480 MHz
RF transmit power range	-24 ~ 20 dBm

5.1.1 Bluetooth LE RF Transmitter (TX) Characteristics

Table 16: Bluetooth LE - Transmitter Characteristics - 1 Mbps

Parameter	Description	Min	Typ	Max	Unit
Carrier frequency offset and drift	Max. $ f_n _{n=0, 1, 2, 3, \dots, k}$	—	4.6	—	kHz
	Max. $ f_0 - f_n _{n=2, 3, 4, \dots, k}$	—	1.2	—	kHz
	Max. $ f_n - f_{n-5} _{n=6, 7, 8, \dots, k}$	—	1.5	—	kHz
	$ f_1 - f_0 $	—	0.5	—	kHz
Modulation characteristics	$\Delta F1_{\text{avg}}$	—	251.8	—	kHz
	Min. $\Delta F2_{\text{max}}$ (for at least 99.9% of all $\Delta F2_{\text{max}}$)	—	234.3	—	kHz
	$\Delta F2_{\text{avg}}/\Delta F1_{\text{avg}}$	—	0.90	—	—
In-band emissions	± 2 MHz offset	—	-31	—	dBm
	± 3 MHz offset	—	-34	—	dBm
	$> \pm 3$ MHz offset	—	-37	—	dBm

Table 17: Bluetooth LE - Transmitter Characteristics - 2 Mbps

Parameter	Description	Min	Typ	Max	Unit
Carrier frequency offset and drift	Max. $ f_n _{n=0, 1, 2, 3, \dots, k}$	—	5.7	—	kHz
	Max. $ f_0 - f_n _{n=2, 3, 4, \dots, k}$	—	1.5	—	kHz

Cont'd on next page

Table 17 – cont'd from previous page

Parameter	Description	Min	Typ	Max	Unit
	Max. $ f_n - f_{n-5} _{n=6, 7, 8, \dots, k}$	—	1.3	—	kHz
	$ f_1 - f_0 $	—	0.6	—	kHz
Modulation characteristics	$\Delta F1_{avg}$	—	502.3	—	kHz
	Min. $\Delta F2_{max}$ (for at least 99.9% of all $\Delta F2_{max}$)	—	489.4	—	kHz
	$\Delta F2_{avg}/\Delta F1_{avg}$	—	0.99	—	—
In-band emissions	± 4 MHz offset	—	-33	—	dBm
	± 5 MHz offset	—	-35	—	dBm
	$> \pm 5$ MHz offset	—	-36	—	dBm

Table 18: Bluetooth LE - Transmitter Characteristics - 125 Kbps

Parameter	Description	Min	Typ	Max	Unit
Carrier frequency offset and drift	Max. $ f_n _{n=0, 1, 2, 3, \dots, k}$	—	6.7	—	kHz
	Max. $ f_0 - f_n _{n=1, 2, 3, \dots, k}$	—	0.9	—	kHz
	$ f_0 - f_3 $	—	0.3	—	kHz
	Max. $ f_n - f_{n-3} _{n=7, 8, 9, \dots, k}$	—	1.1	—	kHz
Modulation characteristics	$\Delta F1_{avg}$	—	251.9	—	kHz
	Min. $\Delta F1_{max}$ (for at least 99.9% of all $\Delta F1_{max}$)	—	260.3	—	kHz
In-band emissions	± 2 MHz offset	—	-25	—	dBm
	± 3 MHz offset	—	-35	—	dBm
	$> \pm 3$ MHz offset	—	-43	—	dBm

Table 19: Bluetooth LE - Transmitter Characteristics - 500 Kbps

Parameter	Description	Min	Typ	Max	Unit
Carrier frequency offset and drift	Max. $ f_n _{n=0, 1, 2, 3, \dots, k}$	—	5.9	—	kHz
	Max. $ f_0 - f_n _{n=1, 2, 3, \dots, k}$	—	0.8	—	kHz
	$ f_0 - f_3 $	—	0.3	—	kHz
	Max. $ f_n - f_{n-3} _{n=7, 8, 9, \dots, k}$	—	1.2	—	kHz
Modulation characteristics	$\Delta F2_{avg}$	—	228.1	—	kHz
	Min. $\Delta F2_{max}$ (for at least 99.9% of all $\Delta F2_{max}$)	—	246.4	—	kHz
In-band emissions	± 2 MHz offset	—	-31	—	dBm
	± 3 MHz offset	—	-35	—	dBm
	$> \pm 3$ MHz offset	—	-37	—	dBm

Note that the In-band emissions in Table 16 and Table 19 above are tested at 15 dBm of TX power. However, the test result still meets the Bluetooth SIG standard even if the TX power is increased up to 20 dBm.

5.1.2 Bluetooth LE RF Receiver (RX) Characteristics

Table 20: Bluetooth LE - Receiver Characteristics - 1 Mbps

Parameter	Description	Min	Typ	Max	Unit	
Sensitivity @30.8% PER	—	—	-98.0	—	dBm	
Maximum received signal @30.8% PER	—	—	8	—	dBm	
C/I and receiver selectivity performance	Co-channel	$F = F_0$ MHz	—	4	—	dB
	Adjacent channel	$F = F_0 + 1$ MHz	—	2	—	dB
		$F = F_0 - 1$ MHz	—	0	—	dB
		$F = F_0 + 2$ MHz	—	-29	—	dB
		$F = F_0 - 2$ MHz	—	-29	—	dB
		$F = F_0 + 3$ MHz	—	-35	—	dB
		$F = F_0 - 3$ MHz	—	-36	—	dB
		$F \geq F_0 + 4$ MHz	—	-30	—	dB
		$F \leq F_0 - 4$ MHz	—	-36	—	dB
Image frequency	—	—	-30	—	dB	
Adjacent channel to image frequency	$F = F_{image} + 1$ MHz	—	-32	—	dB	
	$F = F_{image} - 1$ MHz	—	-35	—	dB	
Out-of-band blocking performance	30 MHz ~ 2000 MHz	—	-16	—	dBm	
	2003 MHz ~ 2399 MHz	—	-12	—	dBm	
	2484 MHz ~ 2997 MHz	—	-16	—	dBm	
	3000 MHz ~ 12.75 GHz	—	0	—	dBm	
Intermodulation	—	—	-35	—	dBm	

Table 21: Bluetooth LE - Receiver Characteristics - 2 Mbps

Parameter	Description	Min	Typ	Max	Unit	
Sensitivity @30.8% PER	—	—	-94.5	—	dBm	
Maximum received signal @30.8% PER	—	—	5	—	dBm	
C/I and receiver selectivity performance	Co-channel	$F = F_0$ MHz	—	5	—	dB
	Adjacent channel	$F = F_0 + 2$ MHz	—	1	—	dB
		$F = F_0 - 2$ MHz	—	-2	—	dB
		$F = F_0 + 4$ MHz	—	-27	—	dB
		$F = F_0 - 4$ MHz	—	-32	—	dB
		$F = F_0 + 6$ MHz	—	-33	—	dB
		$F = F_0 - 6$ MHz	—	-36	—	dB
		$F \geq F_0 + 8$ MHz	—	-36	—	dB
		$F \leq F_0 - 8$ MHz	—	-36	—	dB
Image frequency	—	—	-26	—	dB	
Adjacent channel to image frequency	$F = F_{image} + 2$ MHz	—	-33	—	dB	
	$F = F_{image} - 2$ MHz	—	1	—	dB	
Out-of-band blocking performance	30 MHz ~ 2000 MHz	—	-17	—	dBm	
	2003 MHz ~ 2399 MHz	—	-27	—	dBm	
	2484 MHz ~ 2997 MHz	—	-17	—	dBm	

Cont'd on next page

Table 21 – cont'd from previous page

Parameter	Description	Min	Typ	Max	Unit
	3000 MHz ~ 12.75 GHz	—	0	—	dBm
Intermodulation	—	—	-27	—	dBm

Table 22: Bluetooth LE - Receiver Characteristics - 125 Kbps

Parameter	Description	Min	Typ	Max	Unit	
Sensitivity @30.8% PER	—	—	-105.5	—	dBm	
Maximum received signal @30.8% PER	—	—	8	—	dBm	
C/I and receiver selectivity performance	Co-channel	$F = F_0$ MHz	—	0	—	dB
	Adjacent channel	$F = F_0 + 1$ MHz	—	-4	—	dB
		$F = F_0 - 1$ MHz	—	-6	—	dB
		$F = F_0 + 2$ MHz	—	-31	—	dB
		$F = F_0 - 2$ MHz	—	-34	—	dB
		$F = F_0 + 3$ MHz	—	-39	—	dB
		$F = F_0 - 3$ MHz	—	-48	—	dB
		$F \geq F_0 + 4$ MHz	—	-35	—	dB
		$F \leq F_0 - 4$ MHz	—	-48	—	dB
	Image frequency	—	—	-39	—	dB
	Adjacent channel to image frequency	$F = F_{image} + 1$ MHz	—	-38	—	dB
$F = F_{image} - 1$ MHz		—	-39	—	dB	

Table 23: Bluetooth LE - Receiver Characteristics - 500 Kbps

Parameter	Description	Min	Typ	Max	Unit	
Sensitivity @30.8% PER	—	—	-101.0	—	dBm	
Maximum received signal @30.8% PER	—	—	8	—	dBm	
C/I and receiver selectivity performance	Co-channel	$F = F_0$ MHz	—	2	—	dB
	Adjacent channel	$F = F_0 + 1$ MHz	—	-1	—	dB
		$F = F_0 - 1$ MHz	—	-4	—	dB
		$F = F_0 + 2$ MHz	—	-28	—	dB
		$F = F_0 - 2$ MHz	—	-29	—	dB
		$F = F_0 + 3$ MHz	—	-38	—	dB
		$F = F_0 - 3$ MHz	—	-41	—	dB
		$F \geq F_0 + 4$ MHz	—	-33	—	dB
		$F \leq F_0 - 4$ MHz	—	-41	—	dB
	Image frequency	—	—	-33	—	dB
	Adjacent channel to image frequency	$F = F_{image} + 1$ MHz	—	-36	—	dB
$F = F_{image} - 1$ MHz		—	-38	—	dB	

5.2 802.15.4 Radio

Table 24: 802.15.4 RF Characteristics

Name	Description
Center frequency range of operating channel	2405 ~ 2480 MHz

¹ Zigbee in the 2.4 GHz range supports 16 channels at 5 MHz spacing from channel 11 to channel 26.

5.2.1 802.15.4 RF Transmitter (TX) Characteristics

Table 25: 802.15.4 Transmitter Characteristics - 250 Kbps

Parameter	Min	Typ	Max	Unit
RF transmit power range	-24.0	—	20.0	dBm
EVM	—	3.5%	—	—

5.2.2 802.15.4 RF Receiver (RX) Characteristics

Table 26: 802.15.4 Receiver Characteristics - 250 Kbps

Parameter	Description	Min	Typ	Max	Unit	
Sensitivity @1% PER	—	—	-101.5	—	dBm	
Maximum received signal @1% PER	—	—	8	—	dBm	
Relative jamming level	Adjacent channel	$F = F_0 + 5 \text{ MHz}$	—	31	—	dB
		$F = F_0 - 5 \text{ MHz}$	—	43	—	dB
	Alternate channel	$F = F_0 + 10 \text{ MHz}$	—	49	—	dB
		$F = F_0 - 10 \text{ MHz}$	—	54	—	dB

6 Module Schematics

This is the reference design of the module.

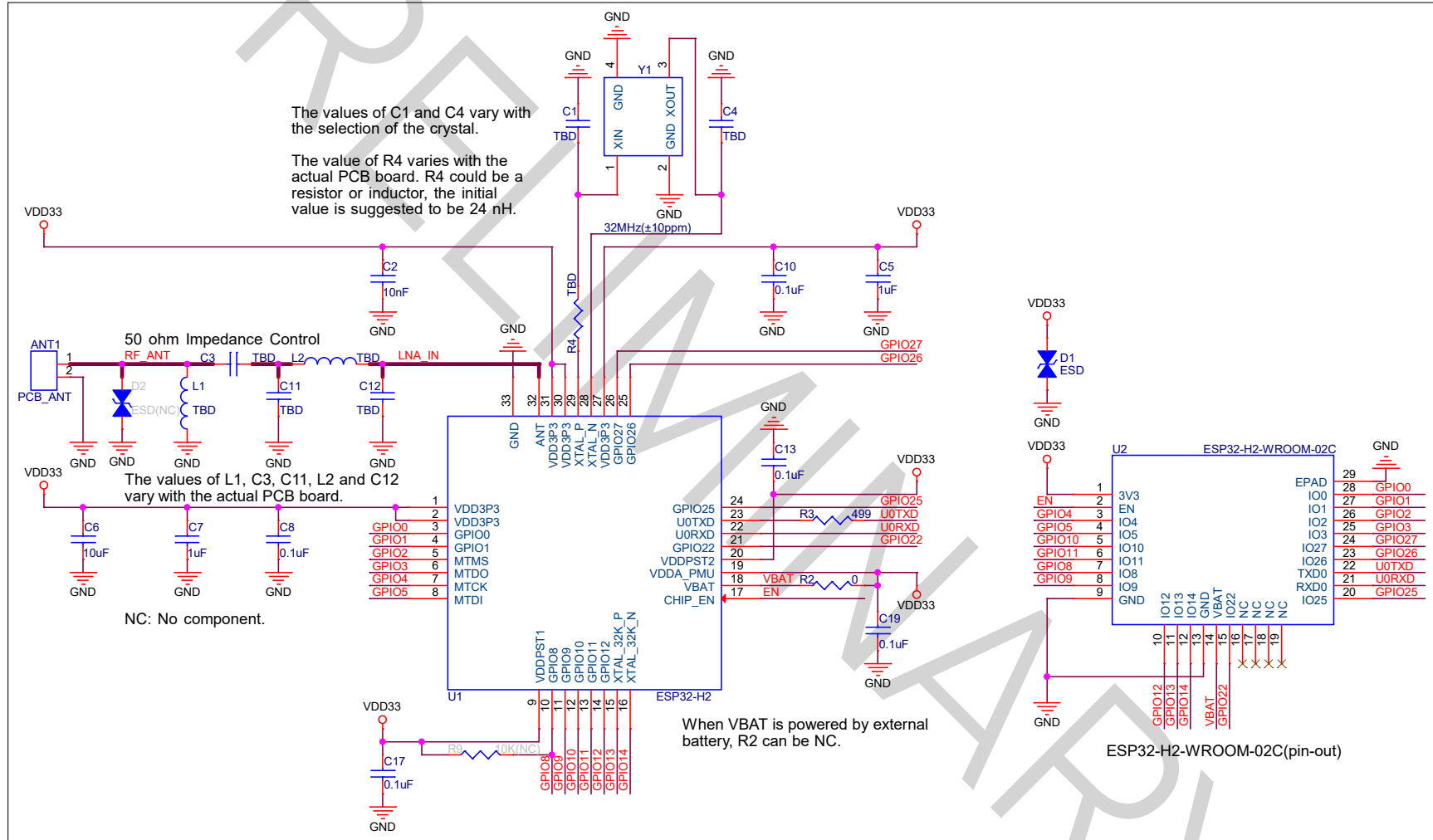

Figure 4: Schematics

7 Peripheral Schematics

This is the typical application circuit of the module connected with peripheral components (for example, power supply, antenna, reset button, JTAG interface, and UART interface).

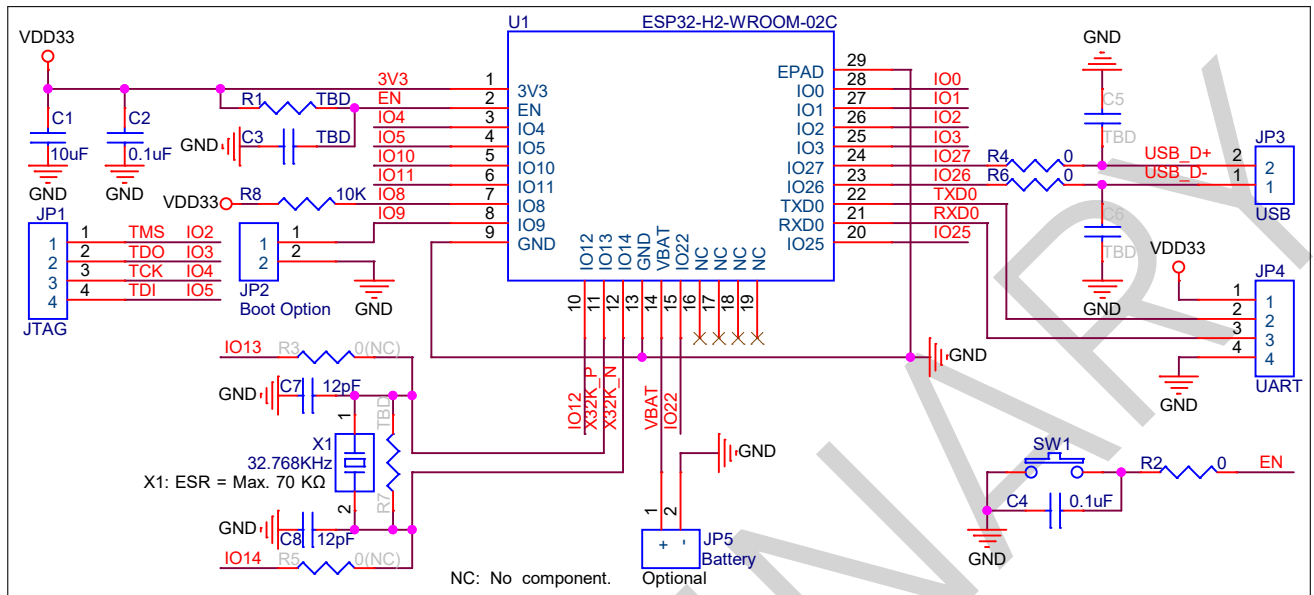

Figure 5: Peripheral Schematics

- To ensure that the power supply to the ESP32-H2 chip is stable during power-up, it is advised to add an RC delay circuit at the EN pin. The recommended setting for the RC delay circuit is usually $R = 10\text{ k}\Omega$ and $C = 1\text{ }\mu\text{F}$ (such RC delay circuit has already been built into the module). However, specific parameters should be adjusted based on the power-up timing of the module and the power-up and reset sequence timing of the chip. For ESP32-H2's power-up and reset sequence timing diagram, please refer to [ESP32-H2 Series Datasheet](#) > Section *Power Supply*.

8 Physical Dimensions and PCB Land Pattern

8.1 Physical Dimensions

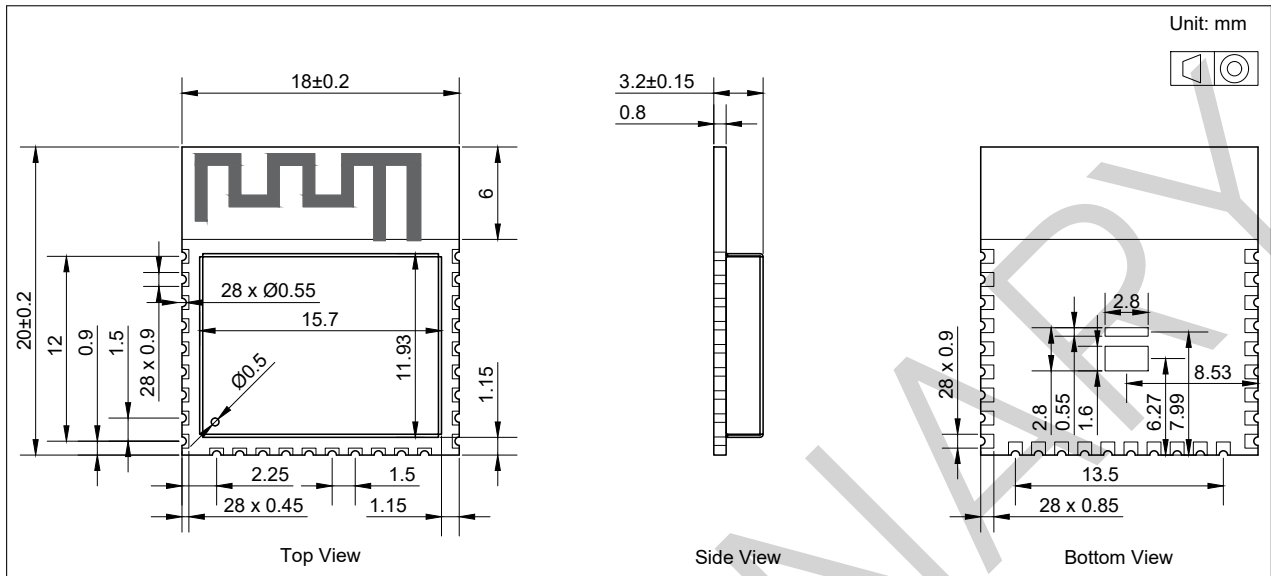

Figure 6: Physical Dimensions

Note:

For information about tape, reel, and product marking, please refer to [Espressif Module Packaging Information](#).

8.2 Recommended PCB Land Pattern

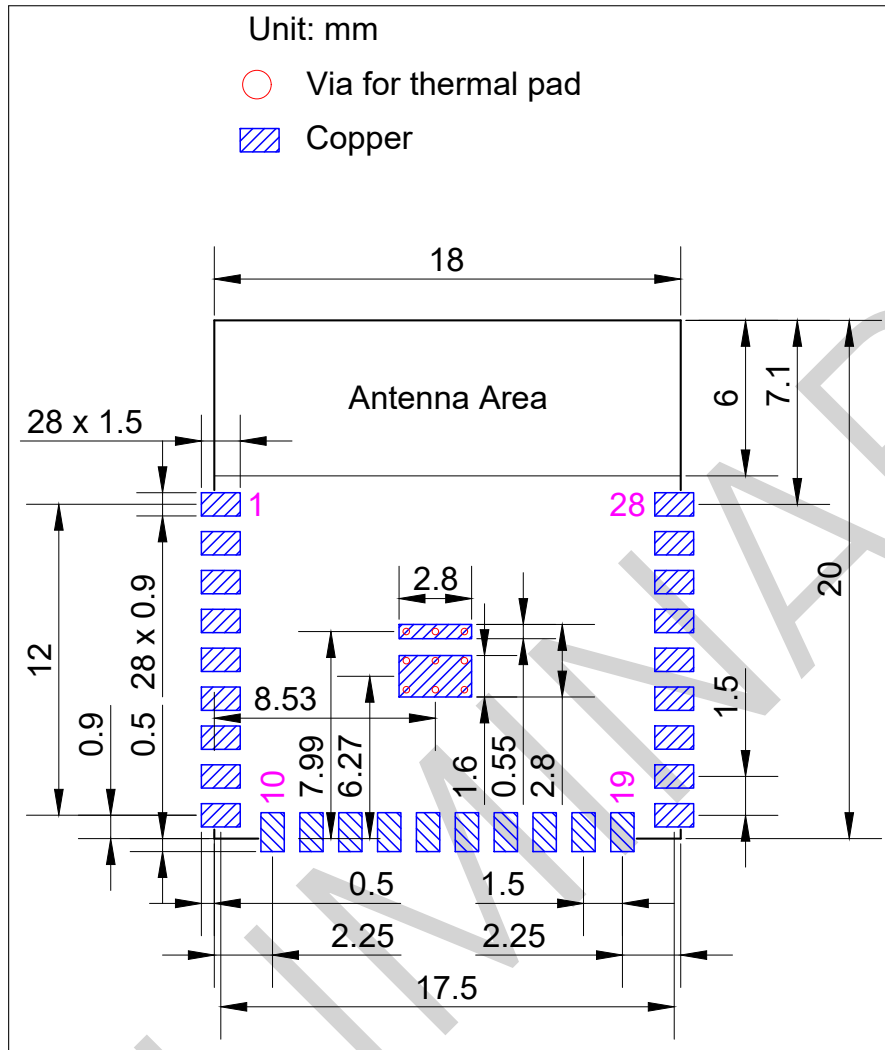

Figure 7: Recommended PCB Land Pattern

9 Product Handling

9.1 Storage Conditions

The products sealed in moisture barrier bags (MBB) should be stored in a non-condensing atmospheric environment of $< 40\text{ }^{\circ}\text{C}$ and 90%RH. The module is rated at the moisture sensitivity level (MSL) of 3.

After unpacking, the module must be soldered within 168 hours with the factory conditions $25\pm 5\text{ }^{\circ}\text{C}$ and 60%RH. If the above conditions are not met, the module needs to be baked.

9.2 Electrostatic Discharge (ESD)

- Human body model (HBM): $\pm 2000\text{ V}$
- Charged-device model (CDM): $\pm 500\text{ V}$

9.3 Soldering Profile

9.3.1 Reflow Profile

Solder the module in a single reflow.

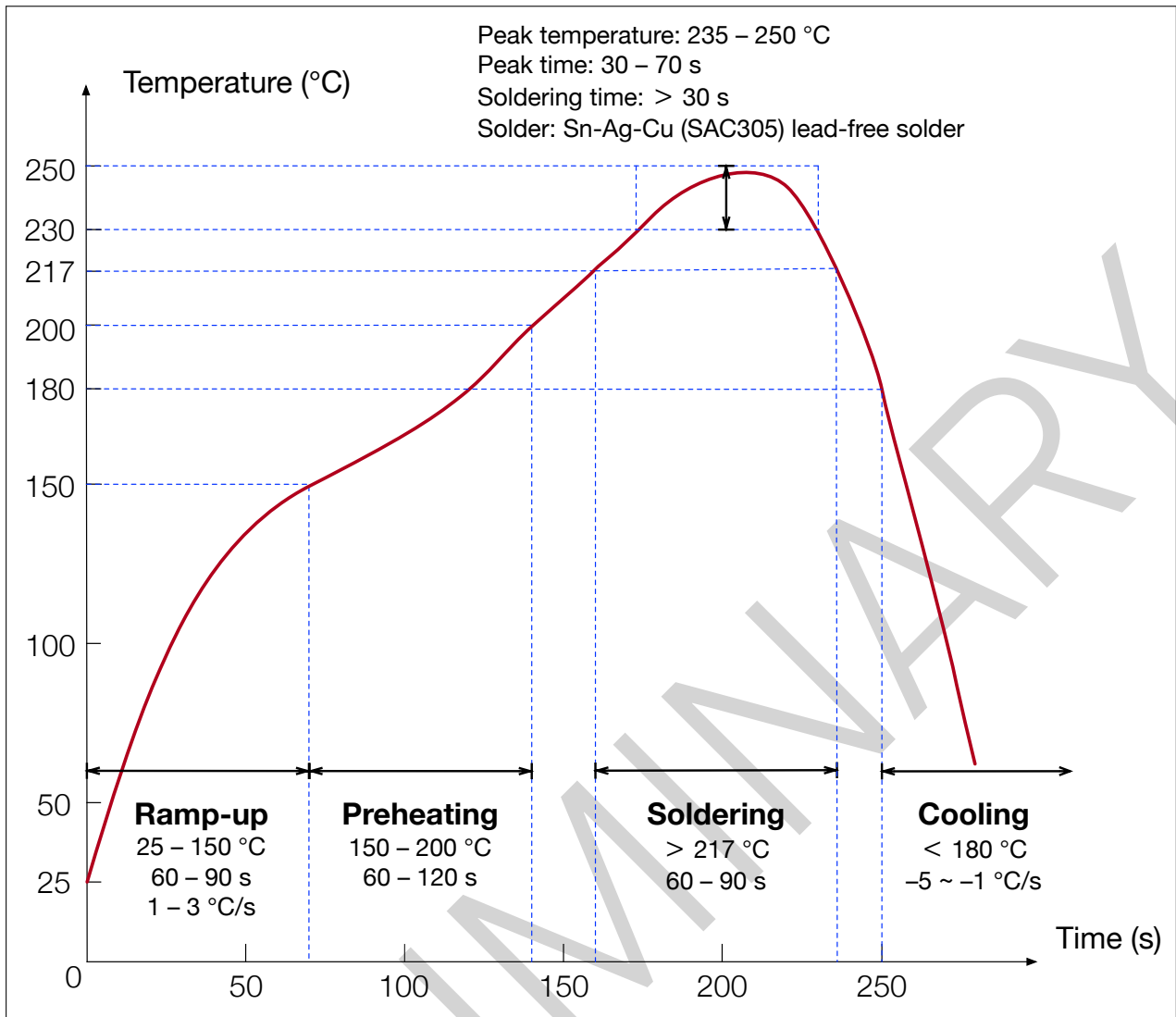

Figure 8: Reflow Profile

9.4 Ultrasonic Vibration

Avoid exposing Espressif modules to vibration from ultrasonic equipment, such as ultrasonic welders or ultrasonic cleaners. This vibration may induce resonance in the in-module crystal and lead to its malfunction or even failure. As a consequence, **the module may stop working or its performance may deteriorate.**

10 Related Documentation and Resources

Related Documentation

- [ESP32-H2 Series Datasheet](#) – Specifications of the ESP32-H2 hardware.
- [ESP32-H2 Technical Reference Manual](#) – Detailed information on how to use the ESP32-H2 memory and peripherals.
- [ESP32-H2 Hardware Design Guidelines](#) – Guidelines on how to integrate the ESP32-H2 into your hardware product.
- [ESP32-H2 Series SoC Errata](#) – Descriptions of known errors in ESP32-H2 series of SoCs.
- *Certificates*
<https://espressif.com/en/support/documents/certificates>
- *ESP32-H2 Product/Process Change Notifications (PCN)*
<https://espressif.com/en/support/documents/pcns?keys=ESP32-H2>
- *ESP32-H2 Advisories* – Information on security, bugs, compatibility, component reliability.
<https://espressif.com/en/support/documents/advisories?keys=ESP32-H2>
- *Documentation Updates and Update Notification Subscription*
<https://espressif.com/en/support/download/documents>

Developer Zone

- [ESP-IDF Programming Guide for ESP32-H2](#) – Extensive documentation for the ESP-IDF development framework.
- *ESP-IDF* and other development frameworks on GitHub.
<https://github.com/espressif>
- *ESP32 BBS Forum* – Engineer-to-Engineer (E2E) Community for Espressif products where you can post questions, share knowledge, explore ideas, and help solve problems with fellow engineers.
<https://esp32.com/>
- *The ESP Journal* – Best Practices, Articles, and Notes from Espressif folks.
<https://blog.espressif.com/>
- See the tabs *SDKs and Demos, Apps, Tools, AT Firmware*.
<https://espressif.com/en/support/download/sdks-demos>

Products

- *ESP32-H2 Series SoCs* – Browse through all ESP32-H2 SoCs.
<https://espressif.com/en/products/socs?id=ESP32-H2>
- *ESP32-H2 Series Modules* – Browse through all ESP32-H2-based modules.
<https://espressif.com/en/products/modules?id=ESP32-H2>
- *ESP32-H2 Series DevKits* – Browse through all ESP32-H2-based devkits.
<https://espressif.com/en/products/devkits?id=ESP32-H2>
- *ESP Product Selector* – Find an Espressif hardware product suitable for your needs by comparing or applying filters.
<https://products.espressif.com/#/product-selector?language=en>

Contact Us

- See the tabs *Sales Questions, Technical Enquiries, Circuit Schematic & PCB Design Review, Get Samples* (Online stores), *Become Our Supplier, Comments & Suggestions*.
<https://espressif.com/en/contact-us/sales-questions>

Revision History

Date	Version	Release notes
2023-12-19	v0.6	Added Documentation Feedback link Updated the fonts used in this document Upgraded the formatting of Figure 8 Fixed a typo in Section 3.2
2023-11-22	v0.5	Preliminary release

PRELIMINARY

DELMININARY



www.espressif.com

Disclaimer and Copyright Notice

Information in this document, including URL references, is subject to change without notice.

ALL THIRD PARTY'S INFORMATION IN THIS DOCUMENT IS PROVIDED AS IS WITH NO WARRANTIES TO ITS AUTHENTICITY AND ACCURACY.

NO WARRANTY IS PROVIDED TO THIS DOCUMENT FOR ITS MERCHANTABILITY, NON-INFRINGEMENT, FITNESS FOR ANY PARTICULAR PURPOSE, NOR DOES ANY WARRANTY OTHERWISE ARISING OUT OF ANY PROPOSAL, SPECIFICATION OR SAMPLE.

All liability, including liability for infringement of any proprietary rights, relating to use of information in this document is disclaimed. No licenses express or implied, by estoppel or otherwise, to any intellectual property rights are granted herein.

The Wi-Fi Alliance Member logo is a trademark of the Wi-Fi Alliance. The Bluetooth logo is a registered trademark of Bluetooth SIG.

All trade names, trademarks and registered trademarks mentioned in this document are property of their respective owners, and are hereby acknowledged.

Copyright © 2023 Espressif Systems (Shanghai) Co., Ltd. All rights reserved.