

ESP8684-WROOM-07

Datasheet

Small-sized 2.4 GHz Wi-Fi (802.11 b/g/n) and Bluetooth® 5 module

Built around ESP8684 series of SoCs, RISC-V single-core microprocessor

2 MB/4 MB flash in chip package

3 GPIOs

Monopole antenna



ESP8684-WROOM-07



Version 0.6
Espressif Systems
Copyright © 2023

1 Module Overview

Note:

Check the link or the QR code to make sure that you use the latest version of this document:

https://espressif.com/documentation/esp8684-wroom-07_datasheet_en.pdf



1.1 Features

CPU and On-Chip Memory

- ESP8684H2 or ESP8684H4 embedded, 32-bit RISC-V single-core processor, up to 120 MHz
- 576 KB ROM
- 272 KB SRAM (16 KB for cache)
- SiP flash (see details in Table 1 [ESP8684-WROOM-07 Series Comparison](#))
- Access to flash accelerated by cache
- Supports flash in-Circuit Programming (ICP)

Wi-Fi

- 802.11 b/g/n
- Center frequency range of operating channel: 2412 ~ 2484 MHz
- Supports 20 MHz bandwidth in 2.4 GHz band
- 1T1R mode with data rate up to 72.2 Mbps
- Wi-Fi Multimedia (WMM)
- TX/RX A-MPDU, TX/RX A-MSDU
- Immediate Block ACK
- Fragmentation and defragmentation
- Transmit opportunity (TXOP)
- Automatic Beacon monitoring (hardware TSF)
- 3 × virtual Wi-Fi interfaces
- Simultaneous support for Infrastructure BSS in Station mode, SoftAP mode, Station + SoftAP mode, and promiscuous mode

Note that when ESP8684 series scans in Station mode, the SoftAP channel will change along with

the Station channel

Bluetooth®

- Bluetooth LE: Bluetooth 5
- High power mode (20 dBm)
- Speed: 125 kbps, 500 kbps, 1 Mbps, 2 Mbps
- Advertising extensions
- Multiple advertisement sets
- Channel selection algorithm #2
- Internal co-existence mechanism between Wi-Fi and Bluetooth to share the same antenna

Peripherals

- GPIO, SPI, UART, I2C, LED PWM controller, general DMA controller, temperature sensor, SAR ADC, general-purpose timers, watchdog timers

Note:

* Please refer to [ESP8684 Series Datasheet](#) for detailed information about the module peripherals.

Integrated Components on Module

- 26 MHz crystal oscillator

Antenna Options

- Monopole antenna

Operating Conditions

- Operating voltage/Power supply: 3.0 ~ 3.6 V
- Operating ambient temperature: -40 ~ 105 °C

1.2 Description

ESP8684-WROOM-07 is a general-purpose Wi-Fi and Bluetooth LE module. The rich set of peripherals and high performance make this module an ideal choice for smart homes, industrial automation, health care, consumer electronics, etc.

ESP8684-WROOM-07 can be vertically soldered to a PCB board via wave soldering and the module has 3 available GPIOs.

ESP8684-WROOM-07 can be connected to an external monopole antenna.

The series comparison for ESP8684-WROOM-07 is as follows:

Table 1: ESP8684-WROOM-07 Series Comparison

Ordering Code	SiP Flash	Ambient Temp. ¹ (°C)	Size ² (mm)
ESP8684-WROOM-07-H2	2 MB	-40 ~105	8.5 × 12.7 × 2.6
ESP8684-WROOM-07-H4	4 MB		

¹ Ambient temperature specifies the recommended temperature range of the environment immediately outside the Espressif module.

² For details, refer to Section [8.1 Physical Dimensions](#).

The ESP8684H2 chip and the ESP8684H4 chip fall into the same category, namely ESP8684 chip series.

ESP8684 integrates a rich set of peripherals including UART, I2C, LED PWM controller, general DMA controller, temperature sensor, and SAR ADC.

Note:

For more information on ESP8684 chip, please refer to [ESP8684 Series Datasheet](#).

1.3 Applications

- Smart Home
 - Light control
 - Smart button
 - Smart plug
 - Indoor positioning
- Industrial Automation
 - Industrial robot
 - Industrial field bus
- Consumer Electronics
 - Smart watch and bracelet
 - Over-the-top (OTT) devices
- Logger toys and proximity sensing toys
- Health Care
 - Health monitor
 - Baby monitor
- Smart Agriculture
 - Smart greenhouse
 - Smart irrigation
 - Agriculture robot
- Retail and Catering
 - POS machines
 - Service robot

- Generic Low-power IoT Sensor Hubs
- Generic Low-power IoT Data Loggers

Contents

1	Module Overview	2
1.1	Features	2
1.2	Description	3
1.3	Applications	3
2	Block Diagram	9
3	Pin Definitions	10
3.1	Pin Layout	10
3.2	Pin Description	10
3.3	Strapping Pins	11
4	Electrical Characteristics	13
4.1	Absolute Maximum Ratings	13
4.2	Recommended Operating Conditions	13
4.3	DC Characteristics (3.3 V, 25 °C)	13
4.4	Current Consumption Characteristics	14
4.4.1	RF Current Consumption in Active Mode	14
4.4.2	Current Consumption in Other Modes	14
5	RF Characteristics	15
5.1	Wi-Fi Radio	15
5.1.1	Wi-Fi RF Standards	15
5.1.2	Wi-Fi RF Transmitter (TX) Specifications	15
5.1.3	Wi-Fi RF Receiver (RX) Specifications	16
5.2	Bluetooth LE Radio	17
5.2.1	Bluetooth LE RF Transmitter (TX) Specifications	17
5.2.2	Bluetooth LE RF Receiver (RX) Specifications	19
6	Module Schematics	21
7	Peripheral Schematics	22
8	Physical Dimensions and PCB Land Pattern	23
8.1	Physical Dimensions	23
8.2	Recommended PCB Land Pattern	24
9	Product Handling	25
9.1	Storage Conditions	25
9.2	Electrostatic Discharge (ESD)	25
9.3	Soldering Profile	25
9.3.1	Wave Profile	25
9.4	Ultrasonic Vibration	26

10 Related Documentation and Resources	27
Revision History	28

List of Tables

1	ESP8684-WROOM-07 Series Comparison	3
2	Pin Definitions	10
3	Test Point Definitions	10
4	Strapping Pins	11
5	Parameter Descriptions of Setup and Hold Times for the Strapping Pins	12
6	Absolute Maximum Ratings	13
7	Recommended Operating Conditions	13
8	DC Characteristics (3.3 V, 25 °C)	13
9	Current Consumption for Wi-Fi (2.4 GHz) in Active Mode	14
10	Current Consumption in Low-Power Modes	14
11	Current Consumption in Modem-sleep Mode	14
12	Wi-Fi RF Characteristics	15
13	TX Power with Spectral Mask and EVM Meeting 802.11 Standards	15
14	TX EVM Test	15
15	RX Sensitivity	16
16	Maximum RX Level	16
17	RX Adjacent Channel Rejection	17
18	Bluetooth LE RF Characteristics	17
19	Bluetooth LE - Transmitter Characteristics - 1 Mbps	17
20	Bluetooth LE - Transmitter Characteristics - 2 Mbps	18
21	Bluetooth LE - Transmitter Characteristics - 125 Kbps	18
22	Bluetooth LE - Transmitter Characteristics - 500 Kbps	18
23	Bluetooth LE - Receiver Characteristics - 1 Mbps	19
24	Bluetooth LE - Receiver Characteristics - 2 Mbps	19
25	Bluetooth LE - Receiver Characteristics - 125 Kbps	20
26	Bluetooth LE - Receiver Characteristics - 500 Kbps	20

List of Figures

1	ESP8684-WROOM-07 Block Diagram	9
2	Pin Layout (Top View and Bottom View)	10
3	Setup and Hold Times for the Strapping Pins	12
4	ESP8684-WROOM-07 Schematics	21
5	Peripheral Schematics	22
6	Physical Dimensions	23
7	Recommended PCB Land Pattern	24
8	Wave Soldering Profile	25

2 Block Diagram

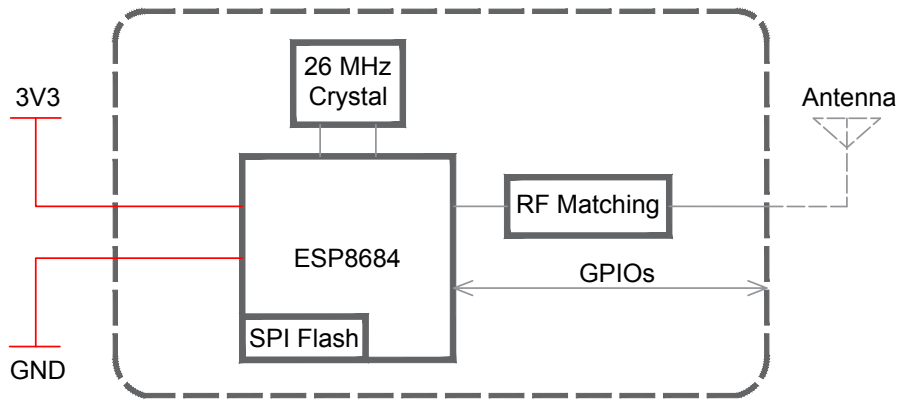

Figure 1: ESP8684-WROOM-07 Block Diagram

3 Pin Definitions

3.1 Pin Layout

The pin diagram below shows the approximate location of pins on the module. For the actual diagram drawn to scale, please refer to Figure 8.1 *Physical Dimensions*.

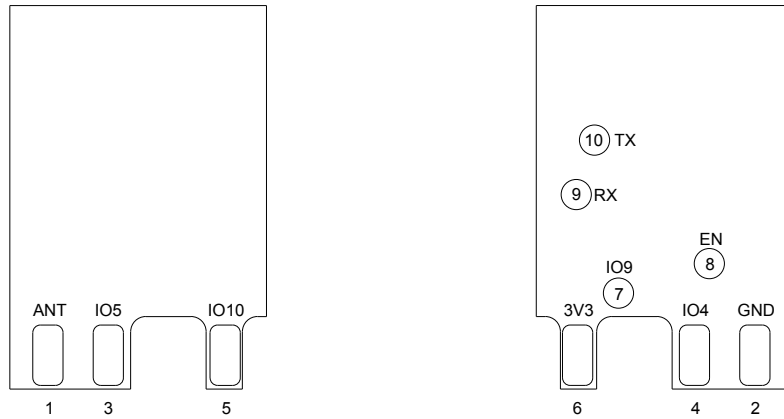

Figure 2: Pin Layout (Top View and Bottom View)

3.2 Pin Description

The module has 6 pins. See pin definitions in Table 2 *Pin Definitions*.

For peripheral pin configurations, please refer to [ESP8684 Series Datasheet](#).

Table 2: Pin Definitions

Name	No.	Type ¹	Function
ANT	1	-	Antenna
GND	2	P	Ground
IO5	3	I/O/T	MTDI, GPIO5, FSPIWP, LED PWM
IO4	4	I/O/T	MTMS, GPIO4, ADC1_CH4, FSPIHD, LED PWM
IO10	5	I/O/T	GPIO10, FSPICS0, LED PWM
3V3	6	P	Power supply

Table 3: Test Point Definitions

Name	No.	Type ¹	Function
IO9	7	I/O/T	GPIO9
EN	8	I	High: on, enables the chip. Low: off, the chip powers off. Default: internally pulled-up.
RX	9	I/O/T	U0RXD, GPIO19
TX	10	I/O/T	U0TXD, GPIO20

¹ P: power supply; I: input; O: output; T: high impedance.

Note:

IO0, IO1, IO3, IO5/MTDI pins have low-level glitches during chip power up. See details in section General Purpose Input / Output Interface (GPIO) of [ESP8684 Series Datasheet](#).

3.3 Strapping Pins

Note:

The content below is excerpted from Section Strapping Pins in [ESP8684 Series Datasheet](#). For the strapping pin mapping between the chip and modules, please refer to Chapter 6 [Module Schematics](#).

ESP8684 series has two strapping pins:

- GPIO8
- GPIO9

Software can read the values of GPIO8 and GPIO9 from GPIO_STRAPPING field in GPIO_STRAP_REG register. For register description, please refer to Section GPIO Matrix Register Summary in [ESP8684 Technical Reference Manual](#).

During the chip's power-on reset, RTC watchdog reset, and brownout reset, the latches of the strapping pins sample the voltage level as strapping bits of "0" or "1", and hold these bits until the chip is powered down or shut down.

By default, GPIO9 is connected to the internal weak pull-up resistor. If GPIO9 is not connected or connected to an external high-impedance circuit, the latched bit value will be "1".

To change the strapping bit values, you can apply the external pull-down/pull-up resistances, or use the host MCU's GPIOs to control the voltage level of these pins when powering on ESP8684.

After reset, the strapping pins work as normal-function pins.

Table 4 lists detailed booting configurations of the strapping pins.

Table 4: Strapping Pins

Booting Mode ¹			
Pin	Default	SPI Boot	Download Boot
GPIO8	N/A	Don't care	1
GPIO9	Internal weak pull-up	1	0
Enabling/Disabling ROM Messages Print During Booting			
Pin	Default	Functionality	
GPIO8	N/A	When the value of eFuse field EFUSE_UART_PRINT_CONTROL is 0 (default), print is enabled and not controlled by GPIO8. 1, if GPIO8 is 0, print is enabled; if GPIO8 is 1, it is disabled. 2, if GPIO8 is 0, print is disabled; if GPIO8 is 1, it is enabled. 3, print is disabled and not controlled by GPIO8.	

¹ The strapping combination of GPIO8 = 0 and GPIO9 = 0 is invalid and will trigger unexpected behavior.

Figure 3 shows the setup and hold times for the strapping pins before and after the CHIP_EN signal goes high. Details about the parameters are listed in Table 5.

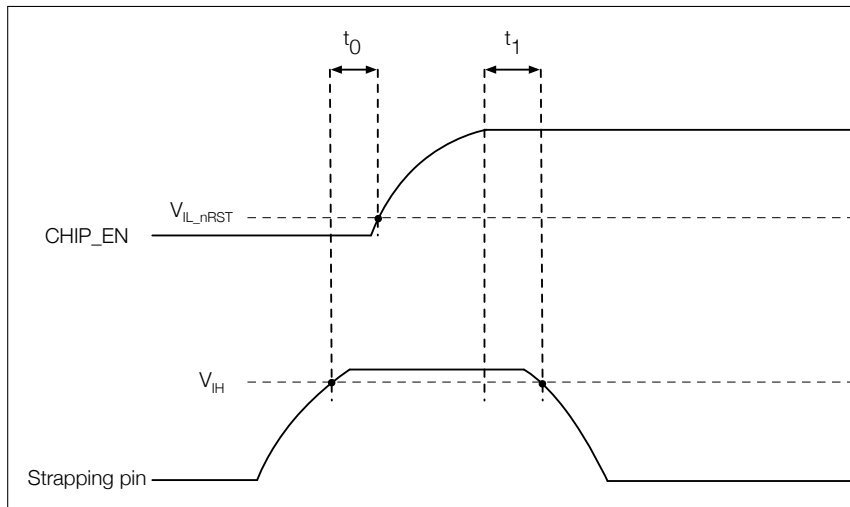

Figure 3: Setup and Hold Times for the Strapping Pins

Table 5: Parameter Descriptions of Setup and Hold Times for the Strapping Pins

Parameter	Description	Min (ms)
t_0	Setup time before CHIP_EN goes from low to high	0
t_1	Hold time after CHIP_EN goes high	3

4 Electrical Characteristics

The values presented in this section are preliminary and may change with the final release of this datasheet.

4.1 Absolute Maximum Ratings

Stresses above those listed in Table 6 *Absolute Maximum Ratings* may cause permanent damage to the device. These are stress ratings only and functional operation of the device at these or any other conditions beyond those indicated under Table 7 *Recommended Operating Conditions* is not implied. Exposure to absolute-maximum-rated conditions for extended periods may affect device reliability.

Table 6: Absolute Maximum Ratings

Symbol	Parameter	Min	Max	Unit
VDD33	Power supply voltage	-0.3	3.6	V
T _{STORE}	Storage temperature	-40	105	°C

4.2 Recommended Operating Conditions

Table 7: Recommended Operating Conditions

Symbol	Parameter	Min	Typ	Max	Unit
VDD33	Power supply voltage	3.0	3.3	3.6	V
I _{VDD}	Current delivered by external power supply	0.5	—	—	A
T _A	Operating ambient temperature	-40	—	105	°C

4.3 DC Characteristics (3.3 V, 25 °C)

Table 8: DC Characteristics (3.3 V, 25 °C)

Symbol	Parameter	Min	Typ	Max	Unit
C _{IN}	Pin capacitance	—	2	—	pF
V _{IH}	High-level input voltage	0.75 × VDD ¹	—	VDD ¹ + 0.3	V
V _{IL}	Low-level input voltage	-0.3	—	0.25 × VDD ¹	V
I _{IH}	High-level input current	—	—	50	nA
I _{IL}	Low-level input current	—	—	50	nA
V _{OH} ²	High-level output voltage	0.8 × VDD ¹	—	—	V
V _{OL} ²	Low-level output voltage	—	—	0.1 × VDD ¹	V
I _{OH}	High-level source current (VDD ¹ = 3.3 V, V _{OH} ≥ 2.64 V, PAD_DRIVER = 3)	—	40	—	mA
I _{OL}	Low-level sink current (VDD ¹ = 3.3 V, V _{OL} = 0.495 V, PAD_DRIVER = 3)	—	28	—	mA
R _{PU}	Pull-up resistor	—	45	—	kΩ
R _{PD}	Pull-down resistor	—	45	—	kΩ

V_{IH_nRST}	Chip reset release voltage	$0.75 \times VDD^1$	—	$VDD^1 + 0.3$	V
V_{IL_nRST}	Chip reset voltage	-0.3	—	$0.25 \times VDD^1$	V

¹ VDD is the I/O voltage for a particular power domain of pins.

² V_{OH} and V_{OL} are measured using high-impedance load.

4.4 Current Consumption Characteristics

4.4.1 RF Current Consumption in Active Mode

The current consumption measurements are taken with a 3.3 V supply at 25 °C ambient temperature.

TX current consumption is rated at a 100% duty cycle.

RX current consumption is rated when the peripherals are disabled and the CPU idle.

Table 9: Current Consumption for Wi-Fi (2.4 GHz) in Active Mode

Work Mode	RF Condition	Description	Peak (mA)
Active (RF working)	TX	802.11b, 1 Mbps, DSSS @ dBm	345
		802.11g, 54 Mbps, OFDM @ dBm	285
		802.11n, HT20, MCS7 @ dBm	275
	RX	802.11b/g/n, HT20	63

4.4.2 Current Consumption in Other Modes

Table 10: Current Consumption in Low-Power Modes

Work mode	Description	Typ	Unit
Light-sleep	—	140	μA
Deep-sleep	Only RTC timer is powered on	5	μA
Power off	CHIP_EN is set to low level, and the chip is powered off	1	μA

Table 11: Current Consumption in Modem-sleep Mode

Work mode	Frequency (MHz)	Description	Typ ¹ (mA)	Typ ² (mA)
Modem-sleep ³	80	WFI (Wait-for-Interrupt)	9.4	10.3
		CPU run at full speed	12.1	13.0
	120	WFI (Wait-for-Interrupt)	10.7	11.5
		CPU run at full speed	14.7	15.6

¹ Current consumption when all peripheral clocks are **disabled**.

² Current consumption when all peripheral clocks are **enabled**. In practice, the current consumption might be different depending on which peripherals are enabled.

³ In Modem-sleep mode, Wi-Fi is clock gated, and the current consumption might be higher when accessing flash. For a flash rated at 80 Mbit/s, in SPI 2-line mode the consumption is 10 mA.

5 RF Characteristics

This section contains tables with RF characteristics of the Espressif product. The RF data is measured at the antenna port, where RF cable is connected, including the front-end loss. The external antennas used for the tests on the modules with external antenna connectors have an impedance of 50 Ω .

Devices should operate in the center frequency range allocated by regional regulatory authorities. The target center frequency range and the target transmit power are configurable by software. See [ESP RF Test Tool and Test Guide](#) for instructions.

Unless otherwise stated, the RF tests are conducted with a 3.3 V ($\pm 5\%$) supply at 25 °C ambient temperature.

5.1 Wi-Fi Radio

5.1.1 Wi-Fi RF Standards

Table 12: Wi-Fi RF Characteristics

Name	Description
Center frequency range of operating channel	2412 ~ 2484 MHz
Wi-Fi wireless standard	IEEE 802.11b/g/n

5.1.2 Wi-Fi RF Transmitter (TX) Specifications

Target TX power is configurable based on device or certification requirements. The default characteristics are provided in Table 13.

Table 13: TX Power with Spectral Mask and EVM Meeting 802.11 Standards

Rate	Min (dBm)	Typ (dBm)	Max (dBm)
802.11b, 1 Mbps, DSSS	—	20.0	—
802.11b, 11 Mbps, CCK	—	20.0	—
802.11g, 6 Mbps, OFDM	—	20.0	—
802.11g, 54 Mbps, OFDM	—	18.0	—
802.11n, HT20, MCS0	—	18.0	—
802.11n, HT20, MCS7	—	17.0	—

Table 14: TX EVM Test¹

Rate	Min (dB)	Typ (dB)	Limit (dB)
802.11b, 1 Mbps, DSSS	—	-25.0	-10.0
802.11b, 11 Mbps, CCK	—	-25.0	-10.0
802.11g, 6 Mbps, OFDM	—	-26.0	-5.0

Cont'd on next page

Table 14 – cont'd from previous page

Rate	Min (dB)	Typ (dB)	Limit (dB)
802.11g, 54 Mbps, OFDM	—	-31.0	-25.0
802.11n, HT20, MCS0	—	-30.0	-5.0
802.11n, HT20, MCS7	—	-32.0	-27.0

¹ EVM is measured at the corresponding typical TX power provided in Table 13 *TX Power with Spectral Mask and EVM Meeting 802.11 Standards* above.

5.1.3 Wi-Fi RF Receiver (RX) Specifications

Table 15: RX Sensitivity

Rate	Min (dBm)	Typ (dBm)	Max (dBm)
802.11b, 1 Mbps, DSSS	—	-98.0	—
802.11b, 2 Mbps, DSSS	—	-96.6	—
802.11b, 5.5 Mbps, CCK	—	-94.2	—
802.11b, 11 Mbps, CCK	—	-89.4	—
802.11g, 6 Mbps, OFDM	—	-94.2	—
802.11g, 9 Mbps, OFDM	—	-92.4	—
802.11g, 12 Mbps, OFDM	—	-91.4	—
802.11g, 18 Mbps, OFDM	—	-88.6	—
802.11g, 24 Mbps, OFDM	—	-86.0	—
802.11g, 36 Mbps, OFDM	—	-82.2	—
802.11g, 48 Mbps, OFDM	—	-78.0	—
802.11g, 54 Mbps, OFDM	—	-76.6	—
802.11n, HT20, MCS0	—	-94.0	—
802.11n, HT20, MCS1	—	-90.8	—
802.11n, HT20, MCS2	—	-88.0	—
802.11n, HT20, MCS3	—	-85.0	—
802.11n, HT20, MCS4	—	-81.0	—
802.11n, HT20, MCS5	—	-77.4	—
802.11n, HT20, MCS6	—	-75.4	—
802.11n, HT20, MCS7	—	-74.2	—

Table 16: Maximum RX Level

Rate	Min (dBm)	Typ (dBm)	Max (dBm)
802.11b, 1 Mbps, DSSS	—	5	—
802.11b, 11 Mbps, CCK	—	5	—
802.11g, 6 Mbps, OFDM	—	5	—

Cont'd on next page

Table 16 – cont'd from previous page

Rate	Min (dBm)	Typ (dBm)	Max (dBm)
802.11g, 54 Mbps, OFDM	—	0	—
802.11n, HT20, MCS0	—	5	—
802.11n, HT20, MCS7	—	-1	—

Table 17: RX Adjacent Channel Rejection

Rate	Min (dB)	Typ (dB)	Max (dB)
802.11b, 1 Mbps, DSSS	—	35	—
802.11b, 11 Mbps, CCK	—	35	—
802.11g, 6 Mbps, OFDM	—	31	—
802.11g, 54 Mbps, OFDM	—	20	—
802.11n, HT20, MCS0	—	31	—
802.11n, HT20, MCS7	—	16	—

5.2 Bluetooth LE Radio

5.2.1 Bluetooth LE RF Transmitter (TX) Specifications

Table 18: Bluetooth LE RF Characteristics

Name	Description
Center frequency range of operating channel	2402 ~ 2480 MHz
RF transmit power range	-24.0 ~ 20.0 dBm

Table 19: Bluetooth LE - Transmitter Characteristics - 1 Mbps

Parameter	Description	Min	Typ	Max	Unit
Carrier frequency offset and drift	Max. $ f_n _{n=0, 1, 2, 3, \dots, k}$	—	1.0	—	kHz
	Max. $ f_0 - f_n _{n=2, 3, 4, \dots, k}$	—	2.3	—	kHz
	Max. $ f_n - f_{n-5} _{n=6, 7, 8, \dots, k}$	—	1.4	—	kHz
	$ f_1 - f_0 $	—	1.5	—	kHz
Modulation characteristics	$\Delta F1_{avg}$	—	250.2	—	kHz
	Min. $\Delta F2_{max}$ (for at least 99.9% of all $\Delta F2_{max}$)	—	234.4	—	kHz
	$\Delta F2_{avg}/\Delta F1_{avg}$	—	1.00	—	—
In-band spurious emissions	± 2 MHz offset	—	-32	—	dBm
	± 3 MHz offset	—	-38	—	dBm
	$> \pm 3$ MHz offset	—	-41	—	dBm

Table 20: Bluetooth LE - Transmitter Characteristics - 2 Mbps

Parameter	Description	Min	Typ	Max	Unit
Carrier frequency offset and drift	Max. $ f_n _{n=0, 1, 2, 3, \dots, k}$	—	3.7	—	kHz
	Max. $ f_0 - f_n _{n=2, 3, 4, \dots, k}$	—	1.8	—	kHz
	Max. $ f_n - f_{n-5} _{n=6, 7, 8, \dots, k}$	—	1.5	—	kHz
	$ f_1 - f_0 $	—	1.1	—	kHz
Modulation characteristics	$\Delta F1_{avg}$	—	500.0	—	kHz
	Min. $\Delta F2_{max}$ (for at least 99.9% of all $\Delta F2_{max}$)	—	460.7	—	kHz
	$\Delta F2_{avg}/\Delta F1_{avg}$	—	1.00	—	—
In-band spurious emissions	± 4 MHz offset	—	-40	—	dBm
	± 5 MHz offset	—	-43	—	dBm
	$> \pm 5$ MHz offset	—	-44	—	dBm

Table 21: Bluetooth LE - Transmitter Characteristics - 125 Kbps

Parameter	Description	Min	Typ	Max	Unit
Carrier frequency offset and drift	Max. $ f_n _{n=0, 1, 2, 3, \dots, k}$	—	0.6	—	kHz
	Max. $ f_0 - f_n _{n=1, 2, 3, \dots, k}$	—	0.7	—	kHz
	$ f_0 - f_3 $	—	0.4	—	kHz
Modulation characteristics	Max. $ f_n - f_{n-3} _{n=7, 8, 9, \dots, k}$	—	0.7	—	kHz
	$\Delta F1_{avg}$	—	250.0	—	kHz
	Min. $\Delta F1_{max}$ (for at least 99.9% of all $\Delta F1_{max}$)	—	241.0	—	kHz
In-band spurious emissions	± 2 MHz offset	—	-32	—	dBm
	± 3 MHz offset	—	-38	—	dBm
	$> \pm 3$ MHz offset	—	-41	—	dBm

Table 22: Bluetooth LE - Transmitter Characteristics - 500 Kbps

Parameter	Description	Min	Typ	Max	Unit
Carrier frequency offset and drift	Max. $ f_n _{n=0, 1, 2, 3, \dots, k}$	—	0.5	—	kHz
	Max. $ f_0 - f_n _{n=1, 2, 3, \dots, k}$	—	0.6	—	kHz
	$ f_0 - f_3 $	—	0.2	—	kHz
Modulation characteristics	Max. $ f_n - f_{n-3} _{n=7, 8, 9, \dots, k}$	—	0.8	—	kHz
	$\Delta F2_{avg}$	—	251.3	—	kHz
	Min. $\Delta F2_{max}$ (for at least 99.9% of all $\Delta F2_{max}$)	—	234.5	—	kHz
In-band spurious emissions	± 2 MHz offset	—	-32	—	dBm
	± 3 MHz offset	—	-38	—	dBm
	$> \pm 3$ MHz offset	—	-41	—	dBm

5.2.2 Bluetooth LE RF Receiver (RX) Specifications

Table 23: Bluetooth LE - Receiver Characteristics - 1 Mbps

Parameter	Description	Min	Typ	Max	Unit	
Sensitivity @30.8% PER	—	—	-98.0	—	dBm	
Maximum received signal @30.8% PER	—	—	8	—	dBm	
C/I and receiver selectivity performance	Co-channel	$F = F_0$ MHz	—	8	—	dB
	Adjacent channel	$F = F_0 + 1$ MHz	—	-1	—	dB
		$F = F_0 - 1$ MHz	—	-3	—	dB
		$F = F_0 + 2$ MHz	—	-26	—	dB
		$F = F_0 - 2$ MHz	—	-28	—	dB
		$F = F_0 + 3$ MHz	—	-34	—	dB
		$F = F_0 - 3$ MHz	—	-33	—	dB
		$F \geq F_0 + 4$ MHz	—	-33	—	dB
	$F \leq F_0 - 4$ MHz	—	-31	—	dB	
Image frequency	—	—	-33	—	dB	
Adjacent channel to image frequency	$F = F_{image} + 1$ MHz	—	-32	—	dB	
	$F = F_{image} - 1$ MHz	—	-34	—	dB	
Out-of-band blocking performance	30 MHz ~ 2000 MHz	—	-23	—	dBm	
	2003 MHz ~ 2399 MHz	—	-30	—	dBm	
	2484 MHz ~ 2997 MHz	—	-10	—	dBm	
	3000 MHz ~ 12.75 GHz	—	-17	—	dBm	
Intermodulation	—	—	-31	—	dBm	

Table 24: Bluetooth LE - Receiver Characteristics - 2 Mbps

Parameter	Description	Min	Typ	Max	Unit	
Sensitivity @30.8% PER	—	—	-95.0	—	dBm	
Maximum received signal @30.8% PER	—	—	8	—	dBm	
C/I and receiver selectivity performance	Co-channel	$F = F_0$ MHz	—	9	—	dB
	Adjacent channel	$F = F_0 + 2$ MHz	—	-11	—	dB
		$F = F_0 - 2$ MHz	—	-7	—	dB
		$F = F_0 + 4$ MHz	—	-35	—	dB
		$F = F_0 - 4$ MHz	—	-30	—	dB
		$F = F_0 + 6$ MHz	—	-35	—	dB
		$F = F_0 - 6$ MHz	—	-29	—	dB
		$F \geq F_0 + 8$ MHz	—	-39	—	dB
	$F \leq F_0 - 8$ MHz	—	-33	—	dB	
Image frequency	—	—	-35	—	dB	
Adjacent channel to image frequency	$F = F_{image} + 2$ MHz	—	-35	—	dB	
	$F = F_{image} - 2$ MHz	—	-11	—	dB	
Out-of-band blocking performance	30 MHz ~ 2000 MHz	—	-30	—	dBm	
	2003 MHz ~ 2399 MHz	—	-34	—	dBm	
	2484 MHz ~ 2997 MHz	—	-19	—	dBm	

Cont'd on next page

Table 24 – cont'd from previous page

Parameter	Description	Min	Typ	Max	Unit
	3000 MHz ~ 12.75 GHz	—	-28	—	dBm
Intermodulation	—	—	-33	—	dBm

Table 25: Bluetooth LE - Receiver Characteristics - 125 Kbps

Parameter	Description	Min	Typ	Max	Unit	
Sensitivity @30.8% PER	—	—	-106.0	—	dBm	
Maximum received signal @30.8% PER	—	—	8	—	dBm	
C/I and receiver selectivity performance	Co-channel	$F = F_0$ MHz	—	3	—	dB
	Adjacent channel	$F = F_0 + 1$ MHz	—	-7	—	dB
		$F = F_0 - 1$ MHz	—	-5	—	dB
		$F = F_0 + 2$ MHz	—	-35	—	dB
		$F = F_0 - 2$ MHz	—	-34	—	dB
		$F = F_0 + 3$ MHz	—	-38	—	dB
		$F = F_0 - 3$ MHz	—	-37	—	dB
		$F \geq F_0 + 4$ MHz	—	-41	—	dB
		$F \leq F_0 - 4$ MHz	—	-45	—	dB
	Image frequency	—	—	-41	—	dB
Adjacent channel to image frequency	$F = F_{image} + 1$ MHz	—	-43	—	dB	
	$F = F_{image} - 1$ MHz	—	-38	—	dB	

Table 26: Bluetooth LE - Receiver Characteristics - 500 Kbps

Parameter	Description	Min	Typ	Max	Unit	
Sensitivity @30.8% PER	—	—	-102.0	—	dBm	
Maximum received signal @30.8% PER	—	—	8	—	dBm	
C/I and receiver selectivity performance	Co-channel	$F = F_0$ MHz	—	4	—	dB
	Adjacent channel	$F = F_0 + 1$ MHz	—	-6	—	dB
		$F = F_0 - 1$ MHz	—	-5	—	dB
		$F = F_0 + 2$ MHz	—	-29	—	dB
		$F = F_0 - 2$ MHz	—	-32	—	dB
		$F = F_0 + 3$ MHz	—	-31	—	dB
		$F = F_0 - 3$ MHz	—	-36	—	dB
		$F \geq F_0 + 4$ MHz	—	-34	—	dB
		$F \leq F_0 - 4$ MHz	—	-33	—	dB
	Image frequency	—	—	-34	—	dB
Adjacent channel to image frequency	$F = F_{image} + 1$ MHz	—	-37	—	dB	
	$F = F_{image} - 1$ MHz	—	-31	—	dB	

6 Module Schematics

This is the reference design of the module.

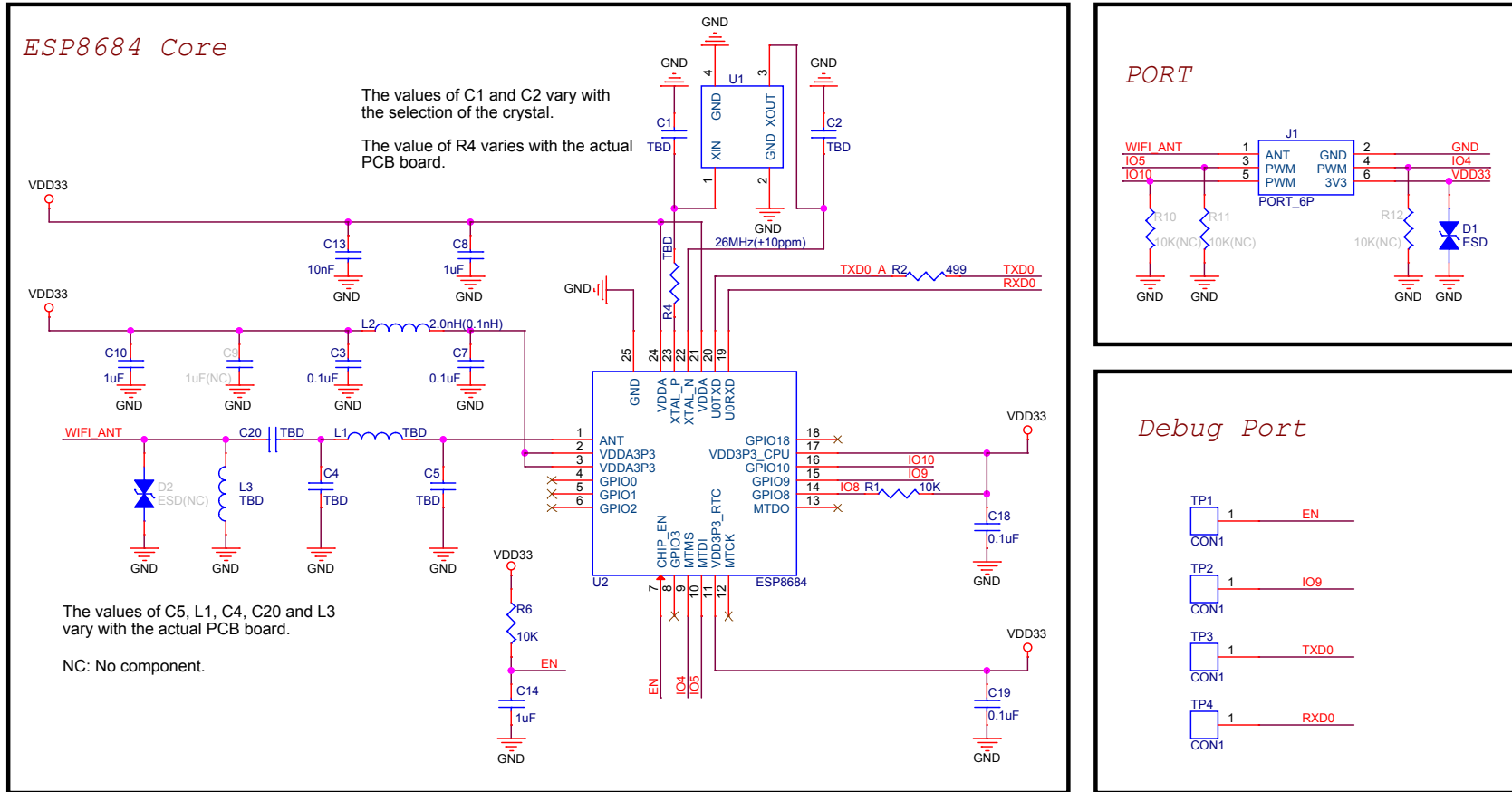

Figure 4: ESP8684-WROOM-07 Schematics

7 Peripheral Schematics

This is the typical application circuit of the module connected with peripheral components (for example, power supply, antenna, reset button, JTAG interface, and UART interface).

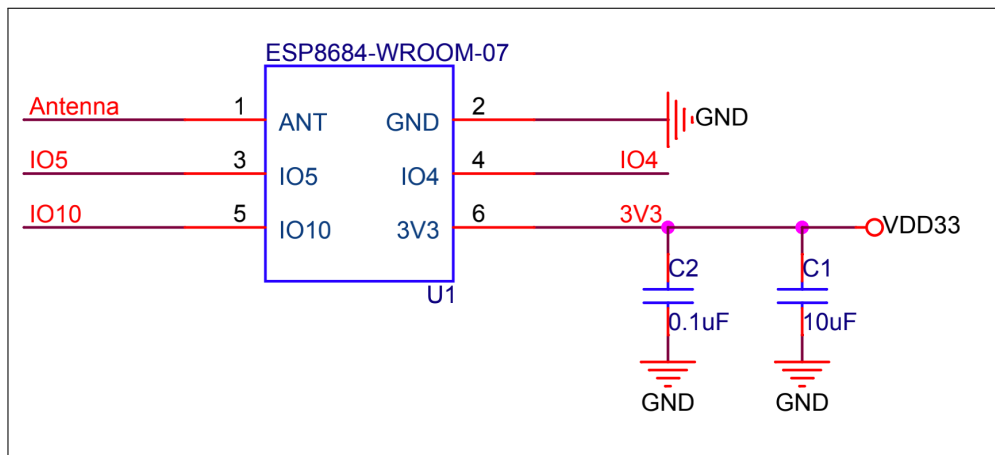

Figure 5: Peripheral Schematics

- To ensure that the power supply to the ESP8684 chip is stable during power-up, it is advised to add an RC delay circuit at the EN pin. The recommended setting for the RC delay circuit is usually $R = 10\text{ k}\Omega$ and $C = 1\ \mu\text{F}$ (such RC delay circuit has already been built into the module). However, specific parameters should be adjusted based on the power-up timing of the module and the power-up and reset sequence timing of the chip. For ESP8684's power-up and reset sequence timing diagram, please refer to Section *Power Scheme* in [ESP8684 Series Datasheet](#).

8 Physical Dimensions and PCB Land Pattern

8.1 Physical Dimensions

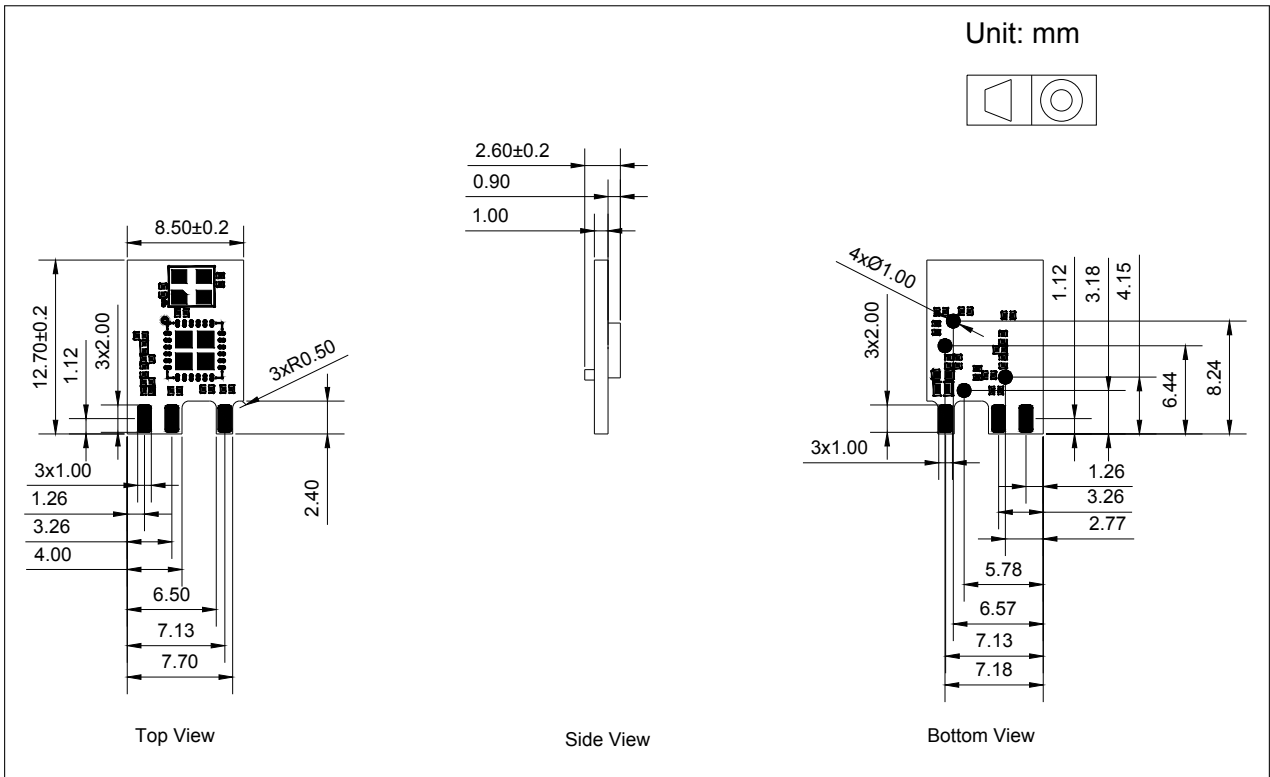

Figure 6: Physical Dimensions

Note:

For information about tape, reel, and product marking, please refer to [Espressif Module Packaging Information](#).

8.2 Recommended PCB Land Pattern

This section provides the following resources for your reference:

- Figure for the recommended PCB land pattern with all the dimensions needed for PCB design. See [Figure 7 Recommended PCB Land Pattern](#).
- Source file of the recommended PCB land pattern to measure dimensions not covered in [Figure 7](#). You can view the source files for [ESP8684-WROOM-07](#) with [Autodesk Viewer](#).

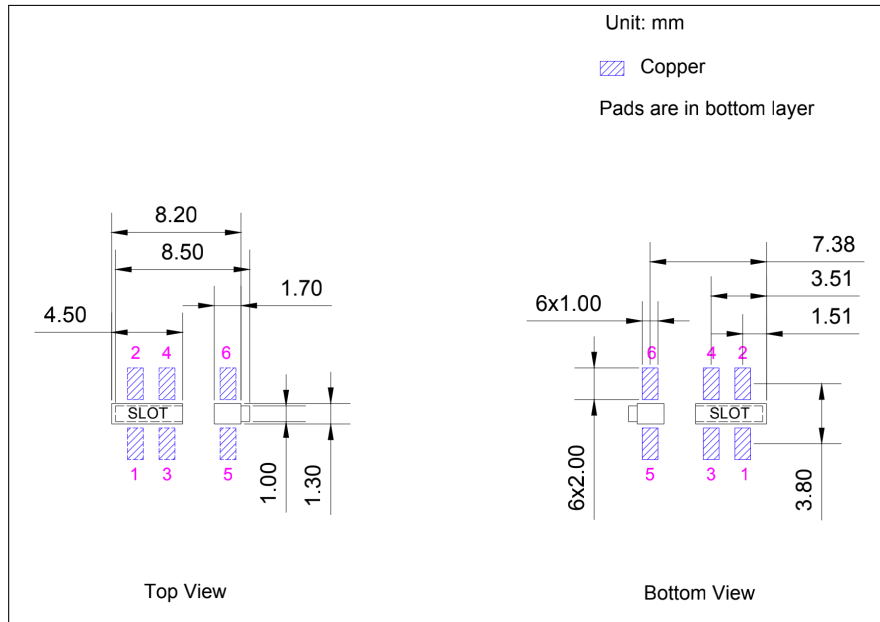

Figure 7: Recommended PCB Land Pattern

9 Product Handling

9.1 Storage Conditions

The products sealed in moisture barrier bags (MBB) should be stored in a non-condensing atmospheric environment of $< 40\text{ }^{\circ}\text{C}$ and 90%RH. The module is rated at the moisture sensitivity level (MSL) of 3.

After unpacking, the module must be soldered within 168 hours with the factory conditions $25\pm 5\text{ }^{\circ}\text{C}$ and 60%RH. If the above conditions are not met, the module needs to be baked.

9.2 Electrostatic Discharge (ESD)

- Human body model (HBM): $\pm 2000\text{ V}$
- Charged-device model (CDM): $\pm 500\text{ V}$

9.3 Soldering Profile

9.3.1 Wave Profile

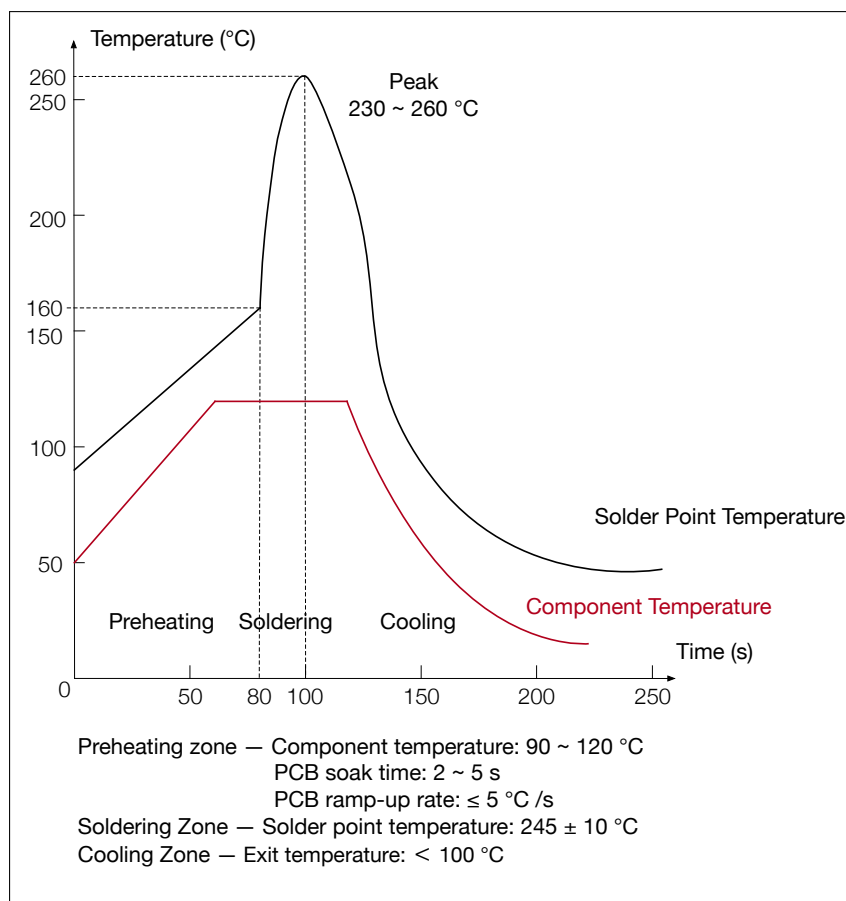

Figure 8: Wave Soldering Profile

9.4 Ultrasonic Vibration

Avoid exposing Espressif modules to vibration from ultrasonic equipment, such as ultrasonic welders or ultrasonic cleaners. This vibration may induce resonance in the in-module crystal and lead to its malfunction or even failure. As a consequence, **the module may stop working or its performance may deteriorate.**

10 Related Documentation and Resources

Related Documentation

- [ESP8684 Series Datasheet](#) – Specifications of the ESP8684 hardware.
- [ESP8684 Technical Reference Manual](#) – Detailed information on how to use the ESP8684 memory and peripherals.
- [ESP8684 Hardware Design Guidelines](#) – Guidelines on how to integrate the ESP8684 into your hardware product.
- *Certificates*
<https://espressif.com/en/support/documents/certificates>
- *ESP8684 Product/Process Change Notifications (PCN)*
<https://espressif.com/en/support/documents/pcns?keys=ESP8684>
- *Documentation Updates and Update Notification Subscription*
<https://espressif.com/en/support/download/documents>

Developer Zone

- [ESP-IDF Programming Guide for ESP8684](#) – Extensive documentation for the ESP-IDF development framework.
- *ESP-IDF* and other development frameworks on GitHub.
<https://github.com/espressif>
- *ESP32 BBS Forum* – Engineer-to-Engineer (E2E) Community for Espressif products where you can post questions, share knowledge, explore ideas, and help solve problems with fellow engineers.
<https://esp32.com/>
- *The ESP Journal* – Best Practices, Articles, and Notes from Espressif folks.
<https://blog.espressif.com/>
- See the tabs *SDKs and Demos*, *Apps*, *Tools*, *AT Firmware*.
<https://espressif.com/en/support/download/sdks-demos>

Products

- *ESP8684 Series SoCs* – Browse through all ESP8684 SoCs.
<https://espressif.com/en/products/socs?id=ESP8684>
- *ESP8684 Series Modules* – Browse through all ESP8684-based modules.
<https://espressif.com/en/products/modules?id=ESP8684>
- *ESP8684 Series DevKits* – Browse through all ESP8684-based devkits.
<https://espressif.com/en/products/devkits?id=ESP8684>
- *ESP Product Selector* – Find an Espressif hardware product suitable for your needs by comparing or applying filters.
<https://products.espressif.com/#/product-selector?language=en>

Contact Us

- See the tabs *Sales Questions*, *Technical Enquiries*, *Circuit Schematic & PCB Design Review*, *Get Samples* (Online stores), *Become Our Supplier*, *Comments & Suggestions*.
<https://espressif.com/en/contact-us/sales-questions>

Revision History

Date	Version	Release notes
2023-06-27	v0.6	<ul style="list-style-type: none">• Updated Section 1.1 Features• Updated 1 ESP8684-WROOM-07 Block Diagram• Updated Section 6 Module Schematics• Updated Section 8.1 Physical Dimensions
2022-01-10	v0.5	Preliminary release
2022-12-27	v0.2	Added a note to table 2 Pin Definitions
2022-04-15	v0.1	Draft



www.espressif.com

Disclaimer and Copyright Notice

Information in this document, including URL references, is subject to change without notice.

ALL THIRD PARTY'S INFORMATION IN THIS DOCUMENT IS PROVIDED AS IS WITH NO WARRANTIES TO ITS AUTHENTICITY AND ACCURACY.

NO WARRANTY IS PROVIDED TO THIS DOCUMENT FOR ITS MERCHANTABILITY, NON-INFRINGEMENT, FITNESS FOR ANY PARTICULAR PURPOSE, NOR DOES ANY WARRANTY OTHERWISE ARISING OUT OF ANY PROPOSAL, SPECIFICATION OR SAMPLE.

All liability, including liability for infringement of any proprietary rights, relating to use of information in this document is disclaimed. No licenses express or implied, by estoppel or otherwise, to any intellectual property rights are granted herein.

The Wi-Fi Alliance Member logo is a trademark of the Wi-Fi Alliance. The Bluetooth logo is a registered trademark of Bluetooth SIG.

All trade names, trademarks and registered trademarks mentioned in this document are property of their respective owners, and are hereby acknowledged.

Copyright © 2023 Espressif Systems (Shanghai) Co., Ltd. All rights reserved.